

***OREGON TRAIL ELECTRIC  
COOPERATIVE, INC.***



**ELECTRIC  
SERVICE  
REQUIREMENTS  
&  
GUIDELINES**

3/1/2023

# OREGON TRAIL ELECTRIC CO-OP

## ELECTRIC SERVICE REQUIREMENTS & GUIDELINES

### TABLE OF CONTENTS

#### ARTICLE

LOCATION OF OTEC OFFICES .....	IV
OTEC SERVICE AREA .....	V

#### SECTION I – GENERAL INFORMATION

1.1 PURPOSE.....	6
1.2 CODES AND ORDINANCES .....	6
1.3 CHANGES OR CONFLICTS IN REQUIREMENTS AND GUIDELINES.....	6
1.4 APPLICATION FOR SERVICE.....	6
1.5 TYPES OF SERVICES FURNISHED .....	7
1.6 APPROVAL FOR SERVICE.....	7
1.7 PERMANENT SERVICE CONNECTION.....	7
1.8 SEALS .....	8

#### SECTION II – SERVICES

2.1 GENERAL.....	9
2.2 PERMITS.....	10
2.3 SEALING OF CABINETS AND GUTTERS.....	10
2.4 CONDUCTOR IDENTIFICATION .....	10
2.5 LOCATION OF METERS .....	11
2.6 TEMPORARY SERVICE (OVERHEAD AND UNDERGROUND) .....	12
2.7 DISCONNECTION AND RECONNECTION OF SERVICE.....	12
2.8 RELOCATION OF SERVICES AND FACILITIES.....	13
2.9 CONSUMER EQUIPMENT ON OTEC POLES.....	13

#### SECTION III – OVERHEAD SERVICE (0 TO 750 VOLTS)

3.1 GENERAL.....	14
3.2 SERVICE DROP .....	14
3.3 SERVICE DROP INSTALLATION CLEARANCES .....	15
3.4 MULTIPLE FAMILY OVERHEAD SERVICE .....	16
3.5 NON-RESIDENTIAL OVERHEAD SERVICE.....	16
3.6 OVERHEAD SERVICE TO METER POLE.....	16
3.7 OVERHEAD SERVICE TO MANUFACTURED HOMES – FACTORY INSTALLED METERS BASE .....	16

#### SECTION IV – UNDERGROUND SERVICE

4.1 GENERAL.....	17
------------------	----

# OREGON TRAIL ELECTRIC CO-OP

## ELECTRIC SERVICE REQUIREMENTS & GUIDELINES

4.2	TRENCHES AND CONDUIT PROVIDED BY CONSUMER .....	17
4.3	CLEARANCES FROM SWIMMING POOLS .....	21
4.4	UNDERGROUND SERVICE - RESIDENTIAL OCCUPANCIES .....	21
4.5	UNDERGROUND SERVICE TO MANUFACTURED HOMES .....	22
4.6	UNDERGROUND SERVICE TO MANUFACTURED HOMES – FACTORY INSTALLED METER BASE .....	23
4.7	NON-RESIDENTIAL UNDERGROUND SERVICE (SINGLE- AND THREE-PHASE) .....	23
<b>SECTION V – SERVICE AT PRIMARY VOLTAGE</b>		
5.1	GENERAL .....	27
5.2	CONSUMER EQUIPMENT .....	27
5.3	UTILITY EQUIPMENT .....	27
<b>SECTION VI – METER INSTALLATION</b>		
6.1	GENERAL .....	28
6.2	ACCEPTABLE METER SOCKETS .....	28
6.2.1	THREE-PHASE CURRENT TRANSFORMER SIZING .....	29
6.2.2	OTEC SUGGESTED METER SOCKET AND CT CABINET LIST .....	30
6.3	SELF-CONTAINED METER SOCKETS .....	31
6.4	MOUNTING OF METER SOCKETS .....	32
6.5	CURRENT TRANSFORMER METERING .....	34
6.6	REACTIVE METERING .....	36
6.7	INSTRUMENT TRANSFORMER INSTALLATIONS OVER 600 VOLTS .....	36
6.8	PULSE INITIATORS/LOAD INFORMATION .....	36
<b>SECTION VII – CONSUMER EQUIPMENT, DEVICES, AND CHARACTER OF SERVICE</b>		
7.1	GENERAL .....	37
7.2	SINGLE-PHASE SERVICE .....	38
7.3	THREE-PHASE SERVICE .....	39
7.4	MOTOR PROTECTION .....	40
7.5	INTERFERING LOAD AND MOTOR STARTING .....	40
7.6	POWER FACTOR .....	41
7.7	EMERGENCY OR STANDBY GENERATORS .....	41
7.8	PARALLEL GENERATION .....	42
7.9	COGENERATION .....	42
7.10	NET METERING .....	42
7.11	AVAILABLE FAULT CURRENT .....	43

# OREGON TRAIL ELECTRIC CO-OP

## ELECTRIC SERVICE REQUIREMENTS & GUIDELINES

### SECTION VIII – OTHER CONSUMER RESPONSIBILITIES

8.1	CONSUMER’S RESPONSIBILITY FOR SAFETY .....	44
8.2	RIGHT-OF-WAY .....	44
8.3	TREES AND SHRUBS .....	44
8.4	CALL BEFORE YOU DIG.....	44

### SECTION IX– TYPICAL INSTALLATION DRAWINGS AND REQUIREMENTS

9.1	RESIDENTIAL OVERHEAD SERVICE.....	45
9.2	ELECTRICAL METER BASE CLEARANCE REQUIREMENTS .....	47
9.3	SUGGESTED METHODS OF INSTALLING OVERHEAD SERVICE WHEN GUYING IS REQUIRED .....	48
9.4	SUGGESTED METHOD OF INSTALLING OVERHEAD SERVICE .....	49
9.5	OVERHEAD SERVICE DETAILS – MULTIPLE OCCUPANCY BUILDINGS .....	50
9.6	OVERHEAD SERVICE FOR POLE MOUNTED INSTALLATION .....	51
9.7	OVERHEAD SERVICE FOR UNDERGROUND SERVICE LATERAL .....	52
9.8	SUGGESTED METHOD OF INSTALLING UNDERGROUND SERVICE SELF CONTAINED METERING.....	53
9.9	UNDERGROUND SERVICE .....	55
9.10	UNDERGROUND SERVICE FOR MANUFACTURED HOME .....	57
9.11	THREE-PHASE CURRENT TRANSFORMER METERING .....	60
9.12	TRANSFORMER MOUNTING BASE FOR INSTALLATION IN CURRENT TRANSFORMER ENCLOSURE.....	62
9.13	METER SOCKET CLEARANCE REQUIREMENTS .....	63
9.14	MUTLTIPLE METER SOCKET INSTALLATIONS.....	64
9.15	FIBERGLASS GROUND SLEEVE INSTALLATION .....	65
9.16	BARRIER POSTS FOR PORTECTION OF PAD-MOUNTED APPARATUS .....	66
9.17	PAD MOUNTED TRANSFORMER CLEARANCES.....	68
<b>INDEX</b> .....		<b>69</b>

# OREGON TRAIL ELECTRIC CO-OP

## ELECTRIC SERVICE REQUIREMENTS & GUIDELINES

### OTEC BUSINESS OFFICES IN OREGON

<b>OFFICE</b>	<b>LOCATION</b>	<b>PHONE</b>
Baker District	4005 23 <sup>rd</sup> St. 97814	(541) 523-3616
Burns District	567 W Pierce 97720	(541) 573-2666
John Day District	400 Patterson Bridge Rd. 97845	(541) 575-0161
La Grande District	2408 Cove Ave 97850	(541) 963-3155

### REPORT POWER OUTAGES

1-866-430-4265

### ELECTRICAL INSPECTION

Call these numbers for up-to-date information:

#### **Baker County**

Electrical Permits and Inspections: 1-541-524-2054

#### **Grant County**

Electrical Permits and Inspections: 1-541-575-1519

#### **Harney County**

Electrical Permits and Inspections: 1-541-573-6655

#### **Union County**

Electrical Permits: 1-541-963-1224 or 1-541-962-1360

Inspections: 1-541-962-1317



## **I. GENERAL INFORMATION**

### **1.1 PURPOSE**

This edition of the Oregon Trail Electric Cooperative (OTEC) Electric Service Requirements and Guidelines manual supersedes all previous editions. The publication and distribution date of this book is January 1<sup>st</sup>, 2015. The requirements in this publication will be enforced on any installation after January 1<sup>st</sup> 2015.

This manual was prepared as an aid in establishing electric service for new and remodeled installations. OTEC recognizes that consumers/contractors may require personal assistance from our staff, and we encourage you to contact us by calling the nearest office listed on page VI of this manual to discuss your electric service requirements. It is the desire of OTEC to provide you with high quality and safe electric service.

### **1.2 CODES AND ORDINANCES**

This manual has been updated to comply with the National Electric Safety Code (NESC), the National Electrical Code (NEC), State of Oregon rules and regulations, and city/county ordinances and codes.

### **1.3 CHANGES OR CONFLICTS IN REQUIREMENTS AND GUIDELINES**

Some of the information in this manual is based on the above governmental codes and ordinances as well as OTEC's policies, procedures and rates. These requirements and guidelines are issued with the intent of complying with all applicable codes, ordinances, policies, and rates. In the case of conflict, the appropriate code, ordinance, policy, and rate will supersede this manual. OTEC does not assume responsibility for keeping this manual current and should be consulted in case of doubt on the applicability of any item.

### **1.4 APPLICATION FOR SERVICE**

It is important that the local OTEC office be contacted as soon as possible when a project requires electrical service so all necessary arrangements for the service may be completed. The applicant needs to provide proof of ownership to property requiring electric service, Service entrance size, and complete load information on OTEC load data form, an approved plot plan, and the property address. Additional information

may be requested in order to expedite service. Requests for service to commercial and industrial consumers normally require considerable advance planning. A lead time of at least 60 days is normally necessary. **Installations that require equipment or transformers not in stock may require six months or more lead time.**

Following the Request for Service and payment of deposit, an OTEC representative will contact the consumer for a site meeting. The consumer needs to be ready to discuss all aspects of service to the property. If changes in the Request for Service are required, those changes must be communicated and approved by the OTEC staking department.

### **1.5 TYPES OF SERVICE FURNISHED**

Electric service available is 60 hertz, alternating current, single or three phase. Nominal voltages are provided below.

<b>TYPE OF SERVICE</b>	<b>NUMBER OF TERMINALS</b>	
	<b><u>(Self Contained)</u></b>	<b><u>(CTs)</u></b>
<b><u>Preferred</u></b>		
Three-wire, Single-phase, grounded 120/240V	4	6
Four-wire, three-phase, grounded 120/208	7	13
Four-wire, three-phase, grounded 277/480V	7	13
<b><u>Engineering Approval Required</u></b>		
Four-wire, three-phase, 120/240V, grounded delta	7	13
Four-wire, three-phase, 240/480V, grounded open-delta	7	13

### **1.6 APPROVAL FOR SERVICE**

Oregon state law requires electrical installations to be approved by the authorized electrical inspector before it can be energized by OTEC.

### **1.7 PERMANENT SERVICE CONNECTION**

Only authorized OTEC employees shall make permanent connections or disconnections to OTEC’s facilities. With OTEC’s prior approval, licensed electricians may make temporary disconnect and connects to a single phase electric service for work. In no case will a consumer/contractor be authorized to make a temporary disconnect or connect to any 3 phase facilities. OTEC assumes no liability for repairs or modifications.



## **1.8 SEALS**

O TEC places seals on meters and associated service equipment to prevent injury and tampering. O TEC will normally assess a tampering fee and institute O TEC's theft of service policy when meter seals are cut or removed without O TEC's prior approval. In the event of an emergency, an O TEC seal is cut or removed, O TEC needs to be notified immediately to avoid the tampering fee. The State Electrical Inspector must also be notified (see Page 12, Section 2.7)

## II. SERVICES

### 2.1 GENERAL

The *point of delivery* is that location on the outside of the consumer's building or structure where OTEC's circuit and consumer's system are interconnected. The length of the route affects the cost and the power quality you will receive from your electrical service. OTEC needs to be CONSULTED IN ADVANCE in order to designate the point of attachment for all types of service and metering installations. Any change in meter location after initial approval must be approved by OTEC.

Any additional service will not normally be supplied to the same consumer at other points of delivery at a different voltage or phase classification.

For secondary voltage service OTEC will install and maintain transformers, meters, and conductors that are defined in Article 100 of the NEC as service drops or service laterals. The consumer will provide, install, and maintain all service equipment, including switches, service entrance conductors, conduit, enclosures, and meter sockets and will provide right-of-way and space for the installation and maintenance of the OTEC facilities.

Consumer will provide over current protection adjacent to the meter base.

Normally, a building will be supplied through only one set of main service conductors of the same voltage and phase classifications. Taps may be taken from these main service conductors where more than one meter installation is necessary in a building of multiple occupancy. Where two or more meters are grouped, each meter position needs to be clearly and permanently identified by means of a metal or painted label to indicate the particular location it supplies. Service will not be established until the marking is completed.

Unmetered service wires and metered load wires will not be run in the same conduit, raceway, or wiring gutter.

All overhead service entrance conductors will be installed in continuous, rigid metallic conduit, electrical metal tubing (EMT), or intermediate metallic conduit (IMC).

## **2.2 PERMITS**

Local ordinances or state laws require applicants to obtain appropriate permits before OTEC connects a service. This may include approval of an electrical installation by the electrical inspection authority. Approval for service will be granted only after all necessary permits and inspections have been obtained.

### Baker County

Electrical Permits & Inspections: 1-541-524-2054

### Grant County

Electrical Permits & Inspections: 1-541-575-1519

### Harney County

Electrical Permits & Inspections: 1-541-573-6655

### Union County

Electrical Permits: 1-541-963-1224 *OR* 1-541-962-1360

Inspections: 1-541-962-1317

## **2.3 SEALING OF CABINETS AND GUTTERS**

All cabinets and gutters containing unmetered conductors, other than mainline switches required by applicable electrical codes, must accommodate sealing with OTEC's seal. Removable conduit fittings may be installed between the service-outlet and the meter when approved by OTEC. These fittings need to be visible from the meter location or from an exterior ground position and need to accommodate sealing.

Unmetered conductors passing through a service disconnect compartment in mobile home service equipment need to be in an enclosed raceway and arranged for sealing.

## **2.4 CONDUCTOR IDENTIFICATION**

Neutral or grounded conductors, if insulated, need to be identified with the color WHITE or GRAY.

Conductors in a WYE (equal voltage) system need to be identified with BLACK, RED, and BLUE.

Conductors in a DELTA (high leg) system need to be identified left to right with BLACK, BLUE, and ORANGE, with the orange high leg connected to the upper right hand meter base lug.

## 2.5 LOCATIONS OF METERS

All meters need to be installed outdoors at a location that is readily accessible to OTEC employees. The meter shall be located on the side of the structure closest to OTEC lines. It is recommended that exterior bedroom or bathroom walls, patios, or carports are avoided as well as exterior walls that are likely to be fenced in. The meter shall not be installed over window wells, steps in stairways, or in other unsafe or inconvenient locations.

Suitable space and provisions for mounting meters need to be provided by the consumer at a location acceptable to OTEC. The minimum unobstructed wall space for a single meter is 30 inches horizontally (see Page 62, Figure 9.13.1).

The distance from the outside of the enclosure on ganged socket installations, shall not be less than 7 feet from a wall or obstruction. Additional wall space for instrument transformers may be required when the ampacity of the service entrance exceeds 200 amps poly-phase, or 400 amps single-phase.

The size of the space will be larger when more than one meter is required. For example, a commercial or industrial installation having an estimated demand of 500 KW or more will require a wall space of approximately 40 inches X 40 inches in addition to the space required for instrument transformers.

A 36 inch working space needs to be maintained in front of self-contained metering installations and a 48 inch working space for installations requiring cabinets. Meter and metering equipment need to be at least 36 inches horizontally from a gas meter (see Page 44, Figure 9.1.1 and Page 46, Figure 9.2.1).

The center of a meter socket needs to be between 5 and 5 ½ feet above finished grade, concrete slab, or deck. PLATFORMS FOR ACCIEVING THIS HEIGHT ARE **NOT ACCEPTABLE** (Exception: the center of meter sockets of manufactured home pedestals shall not be less than or greater than 42 and 66 inches, respectively, above finished grade, concrete slab, or deck).

Meter locations subject to damage need to be suitably barricaded by the consumer. Ganged meter sockets may be mounted lower provided they are properly protected from physical hazard and permission is obtained from OTEC prior to installation. In no case is the bottom of a ganged meter socket to be less than 42 inches above finished grade. It is to the mutual interest of the consumer and OTEC that a suitable outside location be provided to facilitate reading, testing, and replacement of meters with the least inconvenience to the consumer and OTEC.

If, in the opinion of OTEC, a meter is made inaccessible such as by the installation of a fence or enclosure, the consumer shall, at his expense, move the meter socket to an accessible location. Except by special permission, meters are not allowed on mobile structures such as trailers, barges, cranes, dredges, draglines, or any mobile pumping equipment.

Since adoption of the 1984 National Electric Code, the mounting of meters and service equipment on floating dwelling units (houseboats) is prohibited.

## **2.6 TEMPORARY SERVICE (OVERHEAD AND UNDERGROUND)**

Temporary service will be supplied when requested. In addition to the cost of energy used, the consumer will be charged according to OTEC's Electric Line Extension Policy existing at the time of the request.

## **2.7 DISCONNECTION AND RECONNECTION SERVICE**

OTEC will disconnect and reconnect any service supplying consumer-owned service equipment without charge that, for safe working conditions, needs to be de-energized prior to modification. Disconnection and reconnection of service after regular working hours may be charged according to prevailing rates.

Electrical inspection by the local authority (see Page 10, Section 2.2) will be required before reconnection of any service that has been temporarily disconnected for modifications by consumer/contractor request.

If a service has been removed due to abandonment, or has been removed at the consumer's request, it must be upgraded to current OTEC requirements if re-established, and will be subject to OTEC's Electric Line Extension Policy existing at the time of request. Services not using power with OTEC facilities still in place also may be required to be upgraded before service is re-established.

When licensed electricians make modifications, with **prior approval by OTEC**, they may be authorized to remove seal, disconnect and/or temporarily reconnect single-phase services of 400 amps or less that are under 750 volts. (This does not apply to services that have been disconnected and sealed by OTEC.)

## **2.8 RELOCATION OF SERVICES AND FACILITIES**

If relocation of OTEC's facilities located on or adjacent to the consumer's premises is necessary, there may be a charge for such relocation and they will be subject to OTEC's Electric Line Extension Policy existing at the time of the request.

## **2.9 CONSUMER EQUIPMENT ON OTEC POLES**

Unless approved by OTEC, consumer-owned signs, posters, billboards, metering equipment, switching devices, conduits, conductors, luminaries, and so forth, are not to be mounted on OTEC's poles. When such equipment is discovered, the items will be removed and an effort will be made to contact the owners regarding these items.

### III. OVERHEAD SERVICE (0 TO 750 VOLTS)

#### 3.1 GENERAL

New overhead service may be supplied to any building or premises **except** in serviced areas restricted to underground by local government jurisdiction, **OR** when OTEC deems overhead service to not be practical. The point of attachment for all installation(s) needs to be approved by OTEC prior to the installation of the consumer's service equipment. **For pre-manufactured homes, OTEC needs to be consulted in advance of the home ordering to assure proper location of the pre-assembled service entrance.**

#### 3.2 SERVICE DROP

In areas served from overhead lines, an overhead service drop will be installed by OTEC from OTEC distribution line to the point of connection to the consumer's service entrance conductors at the service entrance on the consumer's residence, building, or structure, or pole. OTEC owns and maintains the overhead service lateral from its distribution line to the connection point at the weather-head, and also owns the meter. The consumer owns the meter socket, the meter base, all wiring from the meter socket to the service point, and all wiring beyond the meter socket.

The consumer will provide a location suitable for attachment normally within 2 feet of the weather-head for the service drop that can be reached with a single span of cable normally 80 feet or less from an adjacent OTEC line. The location for attachment needs to be high enough above both initial and finished grade and in a proper position to provide not less than minimum clearances as specified in Section 3.3. The service drop shall not overhang adjacent property and the route needs to be without obstruction by buildings, trees, or other objects. The location for attachment will normally be on the building wall facing nearest OTEC line or on a service mast capable of withstanding the tension.

Supports for service drops need to be extended from and tied into the main structural members of the building. The service mast should extend through the roof on a typical single-story building.

The weather-head, or service mast, shall be no more than 4 feet from the roof edge, and must extend a minimum of 24 inches above the roof, with a maximum of 36 inches if unsupported. Masts extending beyond 36 inches above the roof must be supported

with guying. OTEC may require mast height exceeding 24 inches to be guyed where deemed necessary (See Page 47, Figure 9.3.1 and Page 48, Figure 9.4.1). If a consumer encounters problems in meeting these clearances, OTEC will aid in determining specific requirements that will comply with the code.

### 3.3 SERVICE DROP INSTALLATION CLEARANCES

**NOTE:** This is a performance standard; normally these clearances will be exceeded. The minimum clearances for service drops being installed are as follows:

**Table 3.3.1 – Service Drop (750 volts or less) Minimum Clearance Standards (Feet)**

OBSTACLE	NESC STANDARD
ROADS, STREETS, AREAS SUBJECT TO TRUCK TRAFFIC <sup>1</sup>	16
OVER/ALONG ALLEYS, PARKING LOTS, AND NON-RESIDENTIAL DRIVEWAYS	16
OVER/ALONG RESIDENTIAL DRIVEWAYS – NO TRUCKS	12
OVER FINISHED GRADE	12
VERTICAL CLEARANCE OVER ROOFS, BALCONIES, OR PROJECTIONS READILY ACCESSIBLE TO PEDESTRIANS <sup>2, 3, 4</sup>	11
VERTICAL CLEARANCE OVER ROOFS, BALCONIES, OR PROJECTIONS <b>NOT</b> READILY ACCESSIBLE TO PEDESTRIANS <sup>2, 3, 4</sup>	3.5
ABOVE A ROOF NOT ACCESSIBLE TO PEDESTRIANS AND WHERE NOT MORE THAN SIX FEET OF THE SERVICE DROP PASSES OVER THE ROOF TO TERMINATE AT A 24 INCH MAST THAT IS LOCATED WITHIN FOUR FEET OF THE EDGE OF THE ROOF <sup>3</sup> .	1.5
IN ANY DIRECTION FROM WINDOWS THAT OPEN <sup>3</sup>	5
IN ANY DIRECTION FROM DOORS, PORCHES, FIRE ESCAPES, ETC. <sup>3</sup>	5
HORIZONTAL CLEARANCE TO WALLS, PROJECTIONS, WINDOWS, BALCONIES, AND AREA ACCESSIBLE TO PEDESTRIANS <sup>2, 4</sup>	3.5

The Table 3.3.1 may not cover every situation that may exist. Where there are unusual conditions, consult OTEC.

OTEC strongly suggests that the service entrance be located to avoid having conductors pass over hot tubs, decks, swimming pools, buildings, trees, or other obstructions, if at all possible. Where hot tubs, decks, swimming pools, bridges, or railroads are close by, OTEC needs to be consulted to determine conductor clearance requirements specified by the NESC.

<sup>1</sup> For the purpose of this rule, trucks are defined as any vehicle 8 to 14 feet in height. Areas not subject to truck traffic are defined as areas where truck traffic is not normally encountered or not reasonably anticipated.

<sup>2</sup> A roof or balcony is not considered accessible to pedestrians if the means of access is through a doorway, ramp, window, stairway, or permanently mounted ladder. A permanently mounted ladder is not considered a means of access if its bottom rung is 8 feet or more from the ground or other permanently installed accessible surface.

<sup>3</sup> Refers to clearance requirements for service drops attached to a building or other installation from the roofs or balconies over which they pass.

<sup>4</sup> Refers to clearance requirements from buildings for service drops NOT attached to the building.



### 3.4 MULTIPLE-FAMILY OVERHEAD SERVICE

O TEC will extend an overhead serviced drop from its distribution lines to the point of connection to the consumer's service entrance conductors at the service head. O TEC prefers the grouping of service heads at a common location and will not extend service drop conductors from the point of attachment to the individual service heads. It will be the consumer's responsibility to bring the service entrance conductors from the service head to O TEC's service drop. Normally O TEC will install only one service drop to a building. It will be the consumer's responsibility to obtain permission from the electrical code enforcing authority that has jurisdiction to receive an exception (see Page 49, Figures 9.5.1 thru 9.5.3 and Page 63, Figures 9.14.1 thru 9.14.3).

### 3.5 NONRESIDENTIAL OVERHEAD SERVICE

The point of attachment for nonresidential installations needs to be approved by O TEC prior to the installation of the consumer's service equipment.

Pole-mounted transformer installations are limited to a size that can safely be supported. Installations requiring transformers that cannot be safely mounted on poles need to be served by transformers located in vaults, on pads, platforms, or in fenced enclosures on the consumer's premises.

### 3.6 OVERHEAD SERVICE TO METER POLE

The consumer must install the meter base and service equipment on a new wood pressure treated round pole. The pole must have a minimum length of 25 feet and have a top diameter of 5 ½ inches.

O TEC needs to be consulted **BEFORE** any pole is purchased to assure adequate height at the service location (see Page 50, Figure 9.6.1 and Page 51, Figure 9.7.1).

### 3.7 OVERHEAD SERVICE TO MANUFACTURED HOMES - FACTORY INSTALLED METER BASE

Overhead services to manufactured or mobile homes with factory installed meter bases will be provided under the same requirements as residential occupancies (see Section 3.2). **For pre-manufactured homes, O TEC needs to be consulted in advance of the home ordering to assure proper location of the pre-assembled service entrance.**

## IV. UNDERGROUND SERVICE

### 4.1 GENERAL

The consumer is responsible for providing all trenches, backfill, and conduit for primary and secondary cables. The consumer shall meet the requirements described in this section to complete construction for underground installation.

The consumer is responsible for ensuring that all conduit complies with OTEC's requirements at the time of the cable installation. Conduit systems installed prior to written approval from OTEC shall be subject to OTEC's acceptance. OTEC will only accept a conduit installation once the electrical cable has been installed and energized.

Prior written approval is required from OTEC for conduit systems that exceed the conditions listed on Page 19, Table 4.2.1, *Secondary Cable Conduit Sizes, Run Lengths, and Bend Limits*. A larger conduit size or sweep radius may be required for longer runs or more bends.

### 4.2 TRENCHES AND CONDUIT PROVIDED BY THE CONSUMER

#### Call before you dig.

Oregon law requires that all utilities be notified at least 48 hours prior to excavation and that excavation must not be started until locates have been made or the utility has notified the excavator that they have no facilities in the area.

This notification may be made by calling Utility Notification Center at **811** or **1-800-332-2344**.

#### Depth

Consumer is to provide the trench for OTEC to install conductors in a conduit, the trench needs to be 48 inches deep measured from final grade.

#### Width

Trenches need to be a minimum of 12 inches wide unless a narrower width is approved by OTEC. Narrower trenches will normally be approved for a single service or where splicing or other work will not be done in the trench.

## **Backfill**

The consumer will be responsible for back-filling the trenches they provide. The backfill material must not contain any sharp or foreign objects. Contact OTEC for the method to be used to protect conductors to be placed in rocky ground. Conductors shall not be energized until backfill is complete. (Note: during the backfill process consumer will provide bedding, free of material larger than 3 inches, around conduit)

## **Joint use**

Other utilities may be placed in the same trench as OTEC conductors, provided that the installation is in accordance with OTEC specification and is mutually agreed to by all parties concerned (see Page 20, Figure 4.2.1).

All such installations require the prior approval of OTEC.

## **Requirements for conduit installation**

1. The consumer shall ensure that OTEC's conduit is located away from (and never underneath) buildings, building foundations, or other structures (including retaining walls).
2. All raceways and conduit shall be sealed to prevent the infiltration of water into the electrical equipment.
3. When conduit terminates to OTEC's equipment, the consumer shall consult OTEC for the exact conduit location. The consumer will stop conduit installation a minimum of two feet from OTEC primary UG equipment.
4. When conduit extends vertically through a paved or concrete surface, a sleeve and/or expansion joint shall be placed around the conduit to prevent direct contact with the pavement.
5. The consumer shall keep conduit free of dirt and debris during installation.
6. The consumer is responsible for repairing crushed conduit, including any costs for crews to return to the job site.

7. The consumer shall not install consumer-owned conductors in the same conduit/vault system with OTEC conductors.
8. Consumer is responsible for gluing all joints with a suitable adhesive. OTEC does not require pull strings to be installed in conduit.
9. Joint use of trench with consumer owned conduit is allowed with minimum of 24 inches of separation.
10. OTEC requires inspection of all trench and conduit installations prior to the backfilling of trench. At the time of inspection OTEC will provide caution tape that will be placed approximately 12 inches above the conduit which will be the top of the bedding material.

**Minimum Conduit Required for Utility Conductors (Secondary Voltage – Under 600V)**

**Table 4.2.1 – Secondary Cable Conduit Sizes, Run Lengths, and Bend Limits**

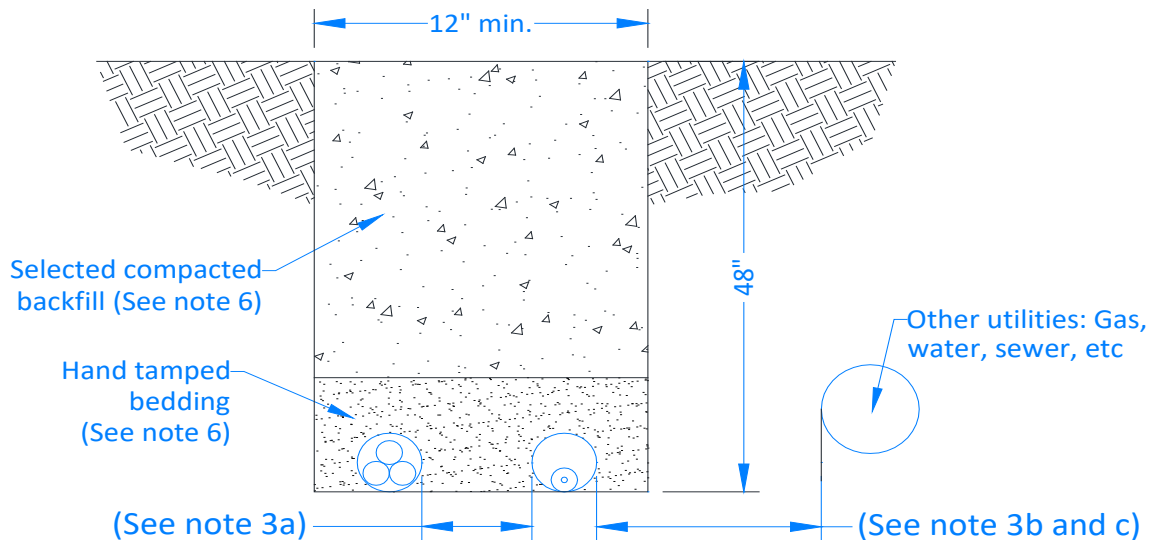
PHASE	LOAD	CONDUIT SIZE	SUGGESTED MAX SERVICE LENGTH (FT)	MAX DEGREE OF BEND
Single	200 or less amps	Consult OTEC	200	270
Single	201 to 400	One 3-inch	200	270
Single	401 to 600 amps	Two 3-inch	100	270
Three	200 amps	One 3-inch	150	270
Three	201 to 400 amps	Two 3-inch	150	270
Three	401 to 600 amps	Two 3-inch	100	270
Three	601 to 800 amps	Three 3-inch	100	270
Three	801 to 1200 amps	Consult OTEC	Consult OTEC	Consult OTEC
Three	1201 amps or more	Consult OTEC	Consult OTEC	Consult OTEC

**Notes:**

1. All conduit needs to be gray schedule 40 PVC.
2. Galvanized elbows and conduit are not allowed.
3. Elbows to be minimum 36 inch sweep radius, application is for up to three elbows.
4. Larger conduit size and elbow radius and/or fiberglass elbows may be required for longer runs. Consumer needs to consult utility for specific requirements.
5. The use of reducers to accommodate conduit size at the meter base is discouraged by OTEC. Consult with OTEC prior to conduit installation for clarification on conduit sizes.
6. Members requesting changes in service sizes are responsible for all changes to conduit.

## Consumer Supplied Facilities and Material

**FIGURE 4.2.1 – TRENCH AND CONDUIT FOR ELECTRIC UNDERGROUND SERVICE**



Notes/requirements for trench and conduit installations:

1. **Call Before You Dig 811 (1-800-332-2344)**. Oregon law requires that **all utilities** be notified at least 48 hours prior to excavation. For public safety, excavation must not be started until all utility locates have been made or the utilities have notified the excavator that they have no facilities in the area.
2. Trenches need to be 48 inches deep measured from final grade and 12 inches in width. Narrower trenches will normally be approved for a single service or where splicing or other work will not be done in the trench. The **trench route** must be staked by OTEC prior to excavation. Any exceptions to these requirements SHALL have the prior approval of OTEC.
3. The following minimum separations are required:
  - a. 3 inches between paralleled OTEC conduits.
  - b. 12 inches for conduit paralleling phone, fiber and TV.
  - c. 24 inches for conduit paralleling sewer, water, and gas.
  - d. Consult OTEC when crossings are unavoidable.
  - e. Consult OTEC for placement of conduit at pole.
4. Conduit must be **GRAY** minimum schedule 40 PVC. **It is critical** the consumer

obtain the correct conduit and elbow diameter and quantity from OTEC before making **any** purchases. All elbows are 90 degrees with minimum 36 inch radius sweep. Conduit must be glued with a suitable adhesive. Pull strings are **NOT** required.

5. The trench **must not** be closed until after the trench and conduit installation is inspected and approved by an OTEC representative. Please coordinate with OTEC so the trench can be closed in the shortest possible time to avoid public hazard, trench collapse, and fall back.
6. The trench needs to have a level undisturbed or tamped bottom and be free of material larger than 3 inches. The first 12 inch layer above the conduit should be free of material larger than 3 inches and have a **marker ribbon**. During burial mechanical tamping equipment shall not be used for the first 12 inches of backfill. After this first placement layer, thorough compaction should be obtained such that trench-settlement does not occur. The balance of the fill should contain material no larger than 8 inches in its maximum dimension. Backfill material containing a corrosive material must not be used.

#### **4.3 CLEARANCES FROM SWIMMING POOLS**

Underground conductors should not be located under a hot tub or swimming pool or within 5 feet of the inside wall of a pool.

#### **4.4 UNDERGROUND SERVICE - RESIDENTIAL OCCUPANCIES**

For underground services to residential occupancies, including single and multiple-family and mobile-home parks, OTEC underground conductors will be in conduit buried in the earth. The consumer will be responsible for all trenching, excavation, backfill, and conduit on the premise or within the confines of the projects of subdivision to be served, and in some cases, for a distance outside the project to connect to OTEC facilities. If a transformer installation is necessary, consult OTEC for consumer responsibilities and detailed installation specifications including set back requirements. Where a pad-mounted equipment is installed in a location where it might be struck by a motorized vehicle, cattle, etc. OTEC may install or require consumer to install barrier post to protect pad mounted equipment (see Page 65, Figure 9.16.1).

For secondary installations, the underground service lateral conductor will be installed,

owned, and maintained by OTEC from OTEC's distribution line to the consumer's termination point.

For services 200 amp or less, the meter socket enclosure minimum dimensions are 11 x 14 x 4 1/8 inches. OTEC will normally terminate service conductors on the line side of the meter socket which will have lugs that accept 1/0-4/0 KCM aluminum conductor wire.

If OTEC service conductor is larger than 4/0 AL, the consumer must provide a 24 x 24 x 11 inch terminal box with terminal landing pads and conductors from the meter base to the terminal box. The box needs to be mounted a minimum of 12 inches above grade.

For services above 200 through 400 amp a 320 amp continuous rated meter socket with manual circuit closing blocks (rigid bus-style link only) will be used (see Page 29, Table 6.2.2.1). The enclosure minimum dimensions are 13 x 22 x 4 1/2 inches and will accept a 3 inch conduit. OTEC will terminate service conductors on the line-side of the meter socket which will have lugs that accept 1/0-350 KCM aluminum conductor.

For code-calculated single-phase loads greater than 320 amps, current transformer metering will be required. The consumer is to provide and install a current transformer cabinet. This cabinet should be located on the exterior of the building (see Page 33, Section 6.5 for cabinet size). Where a current transformer cabinet is installed for underground service, OTEC will terminate the service lateral on the current transformer mounting base (see Page 59, Figure 9.11.1) and the consumer's service entrance conductors will be terminated on the mounting base by the consumer.

The consumer's service entrance equipment should be located on the building structure so that the connection points of this equipment to OTEC's service lateral in on the side nearest those OTEC facilities from which the service lateral will originate. **The consumer needs to contact OTEC for the location and routing of the service lateral prior to the start of building construction.**

Where the conduit extends down through a paved or concrete surfaces, a sleeve needs to be placed around the conduit so that it is not in direct contact with the asphalt or concrete. This prevents damage to the service equipment due to settling.

#### **4.5 UNDERGROUND SERVICE TO MANUFACTURED HOMES**

For underground service to a mobile home, the consumer's service entrance equipment needs to be located on a pedestal (see Page 58, Figure 9.10.2) approved for the purpose or located on a new pressure treated wood post 6 inch x 6 inch x 12 feet long, which is furnished, installed, and maintained by the consumer (see Page 56, Figure 9.10.1).

When the meter may be subject to physical damage, barrier posts or other suitable protection needs to be installed and maintained by the consumer.

Trenches and conduits in mobile home parks provided for OTEC conductors need to be located so as to avoid passing under the pad, foundation, or area provided for the mobile home.

#### **4.6 UNDERGROUND SERVICE TO MANUFACTURED HOMES - FACTORY INSTALLED METER BASE**

Underground service to manufactured homes with factory installed meter bases will be provided under the same requirements as residential occupancies (see Page 21, Section 4.4). Flexible nonmetallic duct, Schedule 40 or stronger electrical grade PVC will be permitted within the physical perimeter of the structure. Consult OTEC for service entrance location before ordering a manufactured home.

#### **4.7 NON-RESIDENTIAL UNDERGROUND SERVICE (SINGLE AND THREE-PHASE)**

For underground service to commercial, industrial buildings or projects, the consumer is responsible for all trenching, back-filling and conduit. If a transformer installation is necessary, the consumer will provide space for the transformer which meets the current requirements of governmental authorities and OTEC. All facilities from the utility's distribution line to the consumer's termination point will be owned and maintained by OTEC. All conduits and bus ways into pad-mounted transformers must enter through the bottom in the OTEC designated location.

Where a pad-mounted transformer, current transformer enclosure, or other equipment is installed in a location where it might be struck by a motorized vehicle, OTEC may install or require consumer to install barrier post to protect pad mounted equipment (see Page 65, Figure 9.16.1).



Where a consumer's conduit extends vertically through a paved surface adjacent to the service entrance, a sleeve needs to be placed around the conduit so the conduit is not in direct contact with the paving. This will help avoid service interruptions or damage to conductors and service equipment caused by settling.

### **Single-Phase**

1. For services 200 amp and less, a meter socket with manual circuit closing blocks (rigid bus style link only) will be used (see Page 29, Table 6.2.2.1). The meter socket enclosure minimum dimensions are 11 x 14 x 4 1/8 inches. OTEC will normally terminate service conductors on the line-side of the meter socket which will have lugs that accept 1/0-4/0 KCM aluminum conductor. If OTEC service conductor is larger than 4/0, the consumer must provide a 24x24x11 inch terminal box with terminal landing pads and conductors from the meter base to the terminal box. The box needs to be mounted a minimum of 12 inches above grade.
2. For services above 200 through 400 amp, a 320 amp continuous rated meter socket with manual circuit closing blocks (rigid bus-style link only) will be used (see Page 29, Table 6.2.2.1) The enclosure minimum dimensions are 13x22x4 1/2 inches and will accept a 3 inch conduit. OTEC will normally terminate service conductors on the line-side of the meter socket which will have lugs that accept 1/0-350 KCM aluminum conductor.

### **Three-Phase 200 amps or less**

For three-phase service equipment rated 200 amps or less, OTEC will terminate the service lateral on the line side of the consumer's meter socket. The meter socket enclosure, with minimum dimensions of 11x14x4 1/8 inches, and line-side meter socket lugs will accept 1/0-350 KCM aluminum conductor. The meter socket is to be a "safety socket" equipped with factory installed test bypass facilities.

### **Three-Phase 200 amps to 800 amps**

For three-phase service equipment rated in excess of 200 amps, OTEC will terminate the service lateral in a current transformer cabinet installed by the consumer (see Page 33, Section 6.5 for cabinet dimensions).

O TEC will provide bar-type current transformers for three-phase service equipment rated up to and including 800 amps. The current transformers are to be installed by O TEC. O TEC will terminate the service lateral on the consumer-supplied current transformer mounting base (see Page 59, Figure 9.11.1 and Page 61, Figure 9.12.1) and the consumer's service entrance conductors will be terminated on the mounting base by the contractor. The neutral, or grounded conductors, need to be terminated as above by each respective party (O TEC and Consumer/Contractor).

### **Three-Phase 800 amps or more**

A EUSERC switchboard metering section is required when the service entrance rating is greater than 800 amperes (may also be used for three phase services over 200 amperes and single phase service over 320 amperes). The metering current transformers will be located in the current transformer compartment. The meter and test switch is to be mounted remotely. Contractor/Owner shall coordinate the location of the meter and the EUSERC section with O TEC before purchasing electrical equipment. Contractor shall provide drawings stamped "Approved for Construction" to O TEC for O TEC approval of the location and layout of the meter and EUSERC section. O TEC shall provide written approval of the installation. If the Contractor chooses to purchase electrical equipment before Power Company approval, it is entirely at Contractor's risk. The area below this compartment's barrier may be used as a main switch (breaker) compartment, a load distribution compartment, or a bottom-fed terminating pull section. The metering compartment shall be on the supply side of the main switch or breaker. Mounting pad for all switchboard metering enclosures will be a minimum 4" thick concrete pad.

### **Switchboard Service Termination**

The Customer will provide the switchboard service section, instrument transformer mounting base, panels, and meter socket, with provisions for a test switch.

Meter and test switch are to be owned, provided, and installed by O TEC in the Customer-owned metering compartment. Window or doughnut type

current transformers for switchboards are provided and installed by OTEC. Current Transformer line and load side connections are to be installed by the Customer and electrical connections are to be tightened to Power Company provided torque specification.

Customer locking mechanism for the metering enclosure must provide for independent access by OTEC.

**EUSERC Notes:**

Terminating bolts must be secured in place and shall be provided with nuts, flat washer, and a spring washer, and all parts must be plated to prevent corrosion. Bus bars are required from the pull section into the service section.

The NEC requires a clear work space of 78” high by 30” minimum width by 48” deep in front of distribution metering equipment. Grounding must meet NEC requirements. Lugs for terminating the Customer’s ground wire (or other grounding conductors) shall be located outside of the sealable section and shall be designed to readily permit the Customer’s neutral system to be isolated, when necessary, from OTEC’s neutral.

All removable panels and covers to the compartments used for terminating or routing conductors shall have sealing provisions. All pull and termination sections shall be full front access. Cover panels shall be removable, sealable, provided with two lifting handles, and limited to a maximum size of 9 square feet in area.

**Multiple Sets of Service Equipment (Three-Phase)**

Where it is necessary to connect two or more sets of service equipment to a single service lateral, the consumer must provide a sealable terminal box complete with terminating positions. An OTEC-approved method must also be separately supplied by the consumer to make multiple taps. Consumer-owned devices (such as limiters, fuses, and so forth) shall not be installed in terminal boxes.

**Table 4.4.1 Single Service Lateral – Multiple Connections**

SERVICE ENTRANCE CONDUCTOR AMPACITY	MINIMUM TERMINAL BOX-SIZE (WxHxD) <b><u>NOT FOR CT CABINETS</u></b>
800 and below	24 x 28 x 11 inches
Greater than 800 AMPS	Consult utility

## **V. SERVICE AT PRIMARY VOLTAGE**

### **5.1 GENERAL**

Depending on the configuration of OTEC primary system, the non-residential consumers may have the option of installing primary metering, (non transformed high voltage) provided that:

1. Service at primary voltage will not, in OTEC's judgment, adversely affect the operation of the distribution system or other consumer's service there from.
2. Such service can be supplied in a safe and reliable manner.
3. All nonresidential consumers requesting service at a primary voltage must agree to special requirements that OTEC may, from time to time, establish as necessary.

### **5.2 CONSUMER EQUIPMENT**

The consumer receiving service at primary or higher voltage shall purchase, own and maintain poles, conductors, cables, capacitors, transformers and associated protective devices.

### **5.3 UTILITY EQUIPMENT**

The consumer will normally provide the pole or pad-mounted enclosure containing primary metering equipment, and in addition will normally pay OTEC the cost of providing a three-phase disconnecting means at or near the point of delivery to disconnect the consumer's system from OTEC's system.

Note: Where limited space makes installation of standard size boxes impractical, consult OTEC to determine the size of a mutually acceptable box that will meet all code requirements.

All labor costs for work required on the consumer system are the responsibility of the consumer.

## VI. METER INSTALLATION

### 6.1 GENERAL

OTEC normally requires the delivery of electrical service through one meter to one consumer at one location. The consumer shall install over-current protection in accordance with electrical inspector specification.

Consumers are not authorized to relocate any meter belonging to OTEC or interfere in any way with the meter or its connection.

A licensed electrician or contractor, **with prior approval**, may remove a single phase meter only to disconnect the service. **(CAUTION: WITH SOME TYPES OF METER BASES, REMOVAL OF THE METER DOES NOT DE-ENERGIZE THE SERVICE.)**

Where practical, the meter needs to be reinstalled in the meter socket after repairs or modification of the service is completed. The consumer or contractor is to promptly notify OTEC when repairs or modifications have been completed. OTEC assumes no liability for repairs or modification.

### 6.2 ACCEPTABLE METER SOCKETS

Acceptable meter sockets need to be manufactured in accordance with the current Standards for Safe Meter Sockets, UL/ANSI-414 or ANSI-C12.7. Sockets intended for underground service are not to be used with overhead service and all conductors are to enter and leave the enclosure through the appropriate openings. The meter socket, complete with terminal lugs, meter jaws, test bypass facilities when required, and sealing means needs to be provided by the consumer (refer to Page 29, Section 6.2.2 for OTEC suggested socket list).

## 6.2.1 THREE PHASE CURRENT TRANSFORMER SIZING

**Table 6.2.1.1 - OTEC Standard for Three-Phase Current Transformer Sizing**

Table	Three-phase application		Thermal rating factor	
	BUSS BAR	CT RATIO	PANEL SIZE AMPS	30° C AMBIENT
<b>GE TYPE JAK-OC WITH BARS</b>				
2 ¼ inches	100:5	200-400	4.0	3.0
2 ¼ inches	200:5	200-600	4.0	3.0
2 ¼ inches	400:5	800	4.0	3.0
<b>GE TYPE JAD-OC WITH BARS<sup>5</sup></b>				
1 – 4 inch bar 4 hole	1000:5	1000-2000	2.0	1.5
2 – 4 inch bar 4 hole	2000:5	2000	1.5	1.0
3 – 4 inch bar 4 hole	3000:5	3000	1.3	1.0
4 – 4 inch bar 4 hole	4000:5	4000	1.0	1.0

### Notes:

1. 320 Amp 120/240 single-phase self-contained meters will be used on 400 Amp single-phase 120/240 Volt panels.
2. For current transformer metering of single phase service, consideration will be given to requests for panels up to 800 Amp with the approval of OTEC's Engineering Department. Requires 400:5 JAK-OC for 400 through 800 Amp service.
3. The meter shall be located a maximum of 150 feet from the instrument transformers.
4. Single phase current transformer installations need to be approved by OTEC's Engineering Department

<sup>5</sup> JAD-OC use 55° C ambient rating because of installation application.

## 6.2.2 OTEC SUGGESTED METER SOCKET AND CT CABINET LIST

**Table 6.2.2.1 OTEC Suggested Meter Socket (Manual Circuit Closing Blocks)**

PHASE	VOLTAGE WIRES	CURRENT	PREFERRED B-LINE CIRCLE AW	SECOND CHOICE MILBANK	TERMINALS	SPECIAL INSTRUCTIONS
SINGLE-PHASE	120/240V 3-Wire	1-125	114TB or U121314	U3504-XL	4	
		125-200	124TB or U264	U3514-XL	4	Overhead / Underground
		201-400	324N	U3548-X	4	Use also on residential 320 amp socket
		OVER 400	12146	UC 3436-XL	6	Use with CTS
	120/240V 3-wire LOAD-CENTERS	125-200	CMBE88B200 BTS or (Siemens) MC0408B1200T	R5168-XTL-200 Or (Square-D) SC816D200C	4	
		201-400	(Siemens) MC0816B1400SDL	(Square-D) SU3040D400CB	4	
	Multi Socket (GANG) Meter Base	Consult Utility				
THREE-PHASE	120/240V OR 240/480V 4-wire delta	1-125	117TB	117TB	7	Hi-leg to ground (wild leg) on right side. Motor loads are limited to 38 HP (Open Delta)
		125-200	127TB	127TB	7	
		over 200	121413-MS83	UC3433-XL	13	Use with large lighting loads and motor loads up to 38 HP (Open Delta). Use with CTs
	120/208V 4-wire wye	1-125	117TB	117TB	7	
		125-200	127TB	U2977-XTL	7	
		over 200	121413-MS83	UC3433-XL	13	Use with current transformers
	277/480 V 4-wire wye	1-125	117TB	U2967-XTL	7	Motor loads: up through 60HP
		125-200	127TB	U2977-XTL	7	Motor Loads: up through 125HP
		over 200	121413-MS83	UC3433-XL	13	Use with current transformer Motor loads: over 125HP

**Table 6.2.2.2 – OTEC Suggested CT Cabinets (Manual Circuit Closing Blocks)**

PHASING	AMPERAGE	CABINET SIZE WxHxD-Inches	PREFERRED B-LINE CIRCLE AW	SECOND CHOICE MILBANK	TYPE	INSTALLATION
SINGLE-PHASE	Greater than 400 Amp	2 CTs 24 x 48 x 11	244811HRTCT Rain Tight	CT244811	CT Cabinet	Install 2-CT base inside cabinet
THREE-PHASE	Up to and including 800 Amp	3 CTs 36 x 48 x 11	364811HRTC T	CT364811 HC	CT Cabinet	Install 3-CT base inside cabinet
	Greater than 800 Amp		CONSULT UTILITY (See also EUSERC switchboard as described on p. 25-26)			

### 6.3 SELF-CONTAINED METER SOCKETS

#### **LIMITATIONS:**

On self-contained meter sockets for motor loads, the continuous duty shall not exceed:

1. 50 horsepower at 208 volts
2. 125 horsepower at 480 volts

**Motor size above these horsepower values will be metered with instrument transformers (see Page 33, Section 6.5).**

**Table 6.3.1 – Standard OTEC Meter Service (Preferred Types)**

Type of Service	Number of Socket Terminals (Self Contained)
Three-wire, single-phase grounded 120/240V & 240/480	4
Three-wire single phase network 120/208V	5
Four-wire, three-phase grounded 120/208 V	7
Four-wire, three-phase grounded 277/480V	7

**Table 6.3.2 – Non-Standard Meter Service  
(Needs Engineering Approval)**

Type of Service	Number of Socket Terminals (Self Contained)
Four-wire, three-phase, 120/240V	7
Four-wire three-phase open delta 240/480V (for loads up to 40hp)	7

#### **NOTES:**

1. For all single-phase meter sockets with a service rated 200 amps and below, the incorporation of manual rigid-style bus circuit-closing blocks in the meter base (automatic circuit closing blocks are not acceptable) will be at the discretion of the consumer. Consumers should note that installations without circuit closing blocks will require an outage for a meter change. Should the consumer require that OTEC perform the meter change outside normal business hours, the consumer will be responsible to pay for overtime at the current OTEC labor rate. This applies to all rate classes.
2. All single-phase services over 200 amps will require manual circuit-closing blocks (rigid bus-style only) incorporated with the meter base. Automatic circuit closing blocks are not acceptable. This applies to all rate classes.



3. All three-phase, self-contained meter bases are required to have manual circuit-closing blocks (rigid bus-style only) incorporated with the meter base. Automatic circuit closing blocks are not acceptable. This applies to all rate classes.
4. All meter sockets need to be ring-type complete with screw or snap type sealable rings.

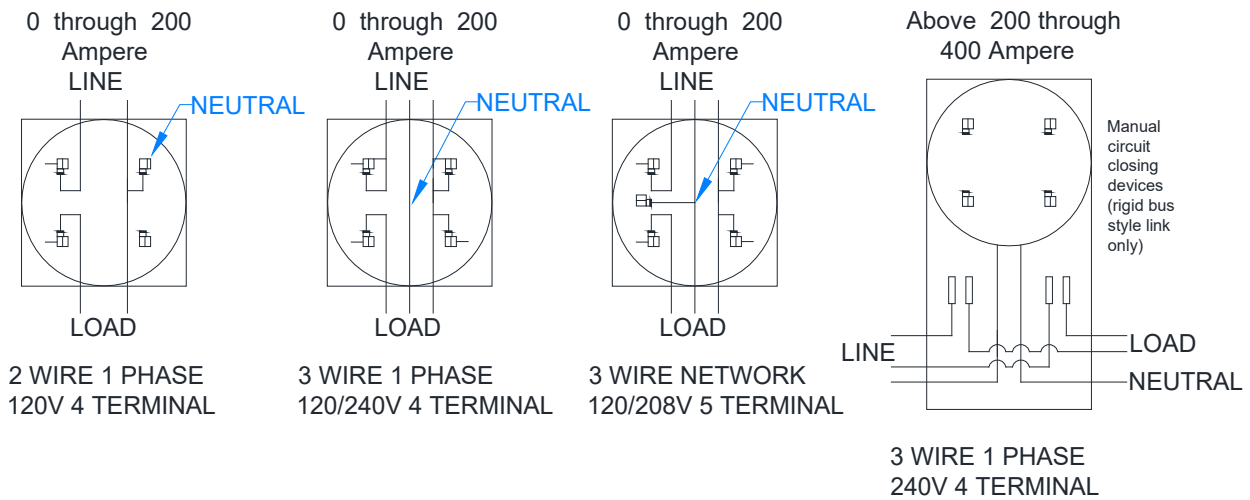
## **6.4 MOUNTING OF METER SOCKETS**

Sockets need to be plumb in all directions and securely mounted to a rigid surface. Conductors need to be securely fastened to their respective terminals and need to be arranged in a manner which will not interfere with the installation of the meter, cover, or with the operation of a circuit-closing block. OTEC conductors need to enter the meter base on the left side (not in the middle) and not interfere with the consumer conductors inside the meter base. See Page 32, Figures 6.4.1 and 6.4.2, below, for wiring illustrations of typical OTEC meter sockets.

If the socket is to be recessed in the building wall, a flush-type box or meter cabinet designed specifically for that purpose needs to be installed and the face of the socket must project outward beyond the building surface.

Meter sockets mounted on buildings must have clearances as shown in Section 9 of this manual. OSHA requires 36 inches of clear working space in front of live parts. No barrier is to be installed within 36 inches of the front of the meter panel. Meter sockets and other metering equipment need to be located at least 36 inches horizontally from a gas meter. OTEC does not allow enclosed meter installations. Meters mounted on consumer poles should be attached with a suitable pole-mounting bracket designed for that purpose. If subject to physical damage, the meter needs to be adequately protected.

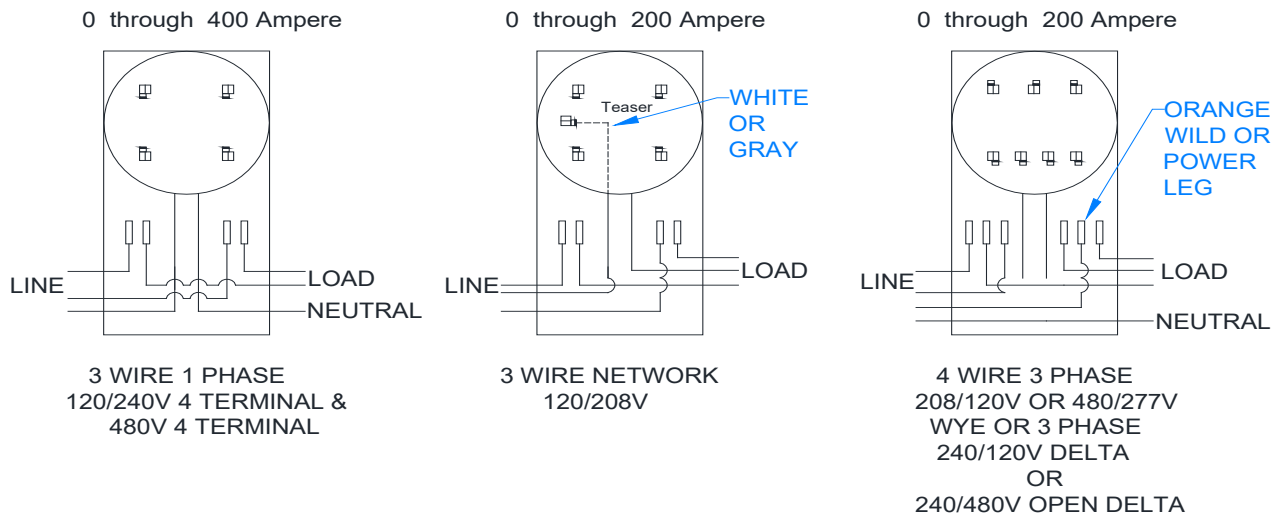
**Figure 6.4.1 - Residential Meter Socket Connections for Self-Contained Meters  
(Ring Type)**



**NOTES:**

1. 0 through 200 amp sockets 11 x 14 x 4 1/8 inch minimum on underground service. Above 200 through 400 amp sockets 13 x 22 x 4 1/2 inch minimum on underground service.
2. Test bypass provisions are not required on residential services of 200 amps or less.

**Figure 6.4.2 – Large and Small Commercial, Irrigation, & Industrial Meter Socket Connections with Manual Circuit Closing Blocks (Rigid Buss Style Links Only)**



## 6.5 CURRENT TRANSFORMER METERING

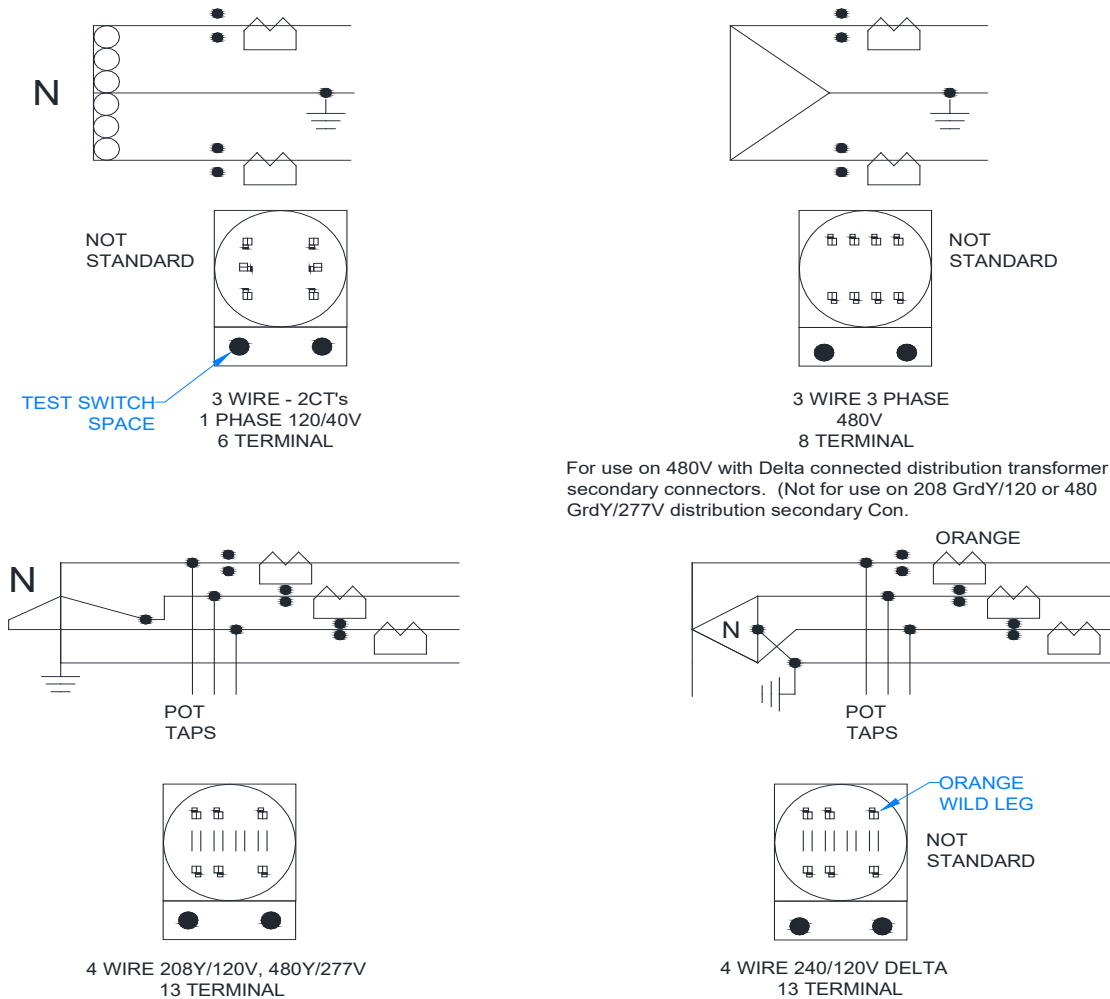
Current transformer (CT) metering is required where the total breaker capacity of three-phase service entrances exceeds 200 amps.

For services of 800 amps and under CT meter installations, bar type CTs are to be supplied and installed by OTEC in a consumer-owned sealable steel cabinet that is securely mounted on a rigid surface (see Figure 6.5.1 below). For CT installations greater than 800 amps see Page 23, Section 4.7. On underground services, OTEC will terminate its outside service entrance conductors on the source-side of the CT. The consumer will terminate their conductors on the load-side of OTEC's CT and ground all meter bases and CT cabinets. This cabinet is to contain only the service conductors and OTEC equipment and is to be mounted in a readily-accessible location acceptable to OTEC (see Page 59, Figure 9.11.1 for cover requirements). Table 6.5.1, below, summarizes the minimum acceptable CT cabinet sizes for specific service types offered by OTEC.

**Table 6.5.1 – Minimum Acceptable CT Cabinet Sizes**

TYPE OF SERVICE	MINIMUM CABINET SIZE WxHxD	MOUNTING BASE (Rated for available fault current)
3 or 4 wire (three-phase) Greater than 200 amps up to and including 800 amps	SEE PAGE 30, TABLE 6.2.2.2	3 CT base
3 or 4 wire (three-phase) greater than 800 amps up to and including 1600 amps	SEE PAGE 30, TABLE 6.2.2.2	
Above 1600 amp (three- phase)	SEE PAGE 30, TABLE 6.2.2.2	

**Figure 6.5.1 – Meter Socket Requirements for Current Transformer Meters**



Meters need to be located outside of buildings. All conduit runs from CT cabinets to meter sockets will be EMT or rigid and shall have a minimum diameter of 1 inch. Removable conduit-cover fittings need to be secured by metal screws with sealing provisions. Only OTEC conductors will be permitted in metering conduit. (OTEC **does not** install CTs inside transformer cabinets.)

The meter socket enclosure for CT metering is to have space below the socket for an OTEC test switch 9 ½ inches in length. The minimum width of the enclosure is to be 11 inches. The enclosure is to contain a perch, drilled and tapped, for a test switch. The test switch will be furnished and installed by OTEC. Meter sockets with circuit closers or bypass clips will not be approved for new installations, modifications, or reconnections of existing service.

The numbers of terminals required in the meter socket are summarized in Table 6.5.2, below.

**Table 6.5.2 – Meter Socket Terminal Requirements for CT Metering**

TYPE OF CT METERED SERVICE	NO. OF TERMINALS
Four-wire, three-phase, grounded	13
Three wire single phase	6

## **6.6 REACTIVE METERING**

Reactive metering needs to be installed when service is three-phase and estimated demand is greater than 500kw.

## **6.7 INSTRUMENT TRANSFORMER INSTALLATIONS OVER 600 VOLTS**

High-voltage instrument transformers and transformer-type meters may be required for large consumers taking service at primary-voltage under provisions of OTEC's rate. OTEC should be consulted before construction begins to establish a mutually satisfactory location for the point of delivery and metering details.

## **6.8 PULSE INITIATORS/LOAD INFORMATION**

Consumer provides equipment for load information for his own purpose. (Example: Pulse information for demand control.)

## VII. CONSUMER EQUIPMENT, DEVICES, AND CHARACTER OF SERVICE

### 7.1 GENERAL

The consumer's electrical equipment and devices are to have characteristics such that OTEC Distribution system is efficiently utilized and undue interference with OTEC service to other consumers does not occur. For all instances in which a consumer requests to add load listed below, or greater, engineering must first determine if the circuit is capable of adequately serving the load:

#### Single-Phase

- 10 HP motor
- 50 KW other load

#### Three-Phase

- 50 HP motor
- 100 KW other load

The consumer's equipment needs to be designated to perform satisfactorily within the standard voltage ranges (120 volt nominal range is 110 to 126) and frequency (60Hz) provided on OTEC's system. In so far as practical, OTEC will endeavor to maintain standard voltages and frequency on its distribution system, subject to variations within reasonable limits.

OTEC reserves the right to inspect and test any equipment connected to its lines and to require any information necessary to determine the operating characteristics of the equipment. Prior to purchase, the consumer should submit information to OTEC regarding any equipment which might cause interference with service to other consumers or require additional facilities for its satisfactory operation. Consumer equipment causing unacceptable interference on OTEC's system will have to be corrected or disconnected from OTEC's system.

Electric service supplied by OTEC may be subjected to voltage disturbances which will not normally affect the performance of lighting, appliances, heating, motors, or other typical electrical equipment, but may result in the improper operation of voltage-sensitive equipment such as microwave ovens, computers, or microprocessors. Voltage-sensitive equipment is defined as equipment which is adversely affected by power disturbances (i.e., sags, spikes, interruptions). It is the responsibility of the consumer to provide those power-conditioning devices that may be required to provide the quality of "power" necessary for optimum performance of his voltage sensitive equipment.

## 7.2 SINGLE-PHASE SERVICE

Large single-phase loads can have operational problems or may cause objectionable voltage dips to neighboring consumers. For this reason, the following requirements apply to equipment connected to single-phase services. For all instances in which a consumer requests to add the load listed below, or greater, engineering must first determine if the circuit is capable of adequately serving the load:

### Single-Phase

- 10 HP motor
- 50 KW other load

### **Requirements:**

1. Normally, any single-phase load with a breaker capacity of 400 amps or less needs to be served at 120/240 volts. The load needs to be balanced on the phase conductors as closely as practical. Load balance needs to be modified if load on one phase exceeds twice the load on another phase.
2. Single-phase services above 400 amps require current transformer metering.
3. No individual motor larger than 10 horsepower may be connected without prior approval in writing from OTEC. In addition, air conditioners and heat pumps larger than 3 tons require prior OTEC approval (air conditioners and single-phase motors larger than 3 horsepower may cause unavoidable voltage dips objectionable to some consumers).
4. Any residential space or water-heating appliance having a total capacity greater than 12 kw needs to be so designed and controlled that not more than 12 kw will be switched on or off at any one time.
5. OTEC will require the consumer to use three-phase service if, in OTEC's judgment, the consumer's load is excessive or the consumer's motors, equipment, or operating characteristics could cause objectionable voltage dips to neighboring consumers.

### 7.3 THREE-PHASE SERVICE

Three-phase service will normally be provided in accordance with OTEC's Line Extension Policy upon request for motors greater than 10 hp. For all instances in which a consumer requests to add the load listed below, or greater, engineering must first determine if the circuit is capable of adequately serving the load:

#### Three-Phase

- 50 HP motor
- 100 KW other load

#### **Requirements:**

1. Three phased service over 200 amps maximum requires current transformer metering.
2. The consumer's connection of single-phase loads to three-phase should follow the guidelines shown below in order to prevent an overloading or single-phasing condition which could damage the consumer's three-phase equipment.
3. On 208Y/120-volt or 480Y/277-volt, three-phase services, all single-phase loads should be split evenly among the three phases.
4. On 240/120-volt, delta, three-phase service, all single-phase loads (both 120 and 240 volt) should connect only to the 120-volt-to-ground legs; except 240-volt resistance heating equipment which may be balanced across all three phases.
5. The high or wild leg (208 volts to ground) of a 240/120 volt, four-wire delta must be identified with the color orange. 208 to ground needs to be in the right hand position of the meter base.
6. OTEC will choose the voltage supplied to the consumer depending upon the characteristics of OTEC's distribution system in the area and the consumer's electrical needs.



## **7.4 MOTOR PROTECTION**

To assure adequate safety to personnel and equipment, the consumer is responsible for providing and maintaining code-approved protective devices to protect all motors against overloading, short circuits, ground faults, low voltage, and for protecting all three phase motors against single phase conditions. OTEC will not be held liable for damage to consumer's equipment because of a single phase condition.

Three-phase submersible pumps require a three-transformer bank (closed wye- wye) installation.

## **7.5 INTERFERING LOADS AND MOTOR STARTING**

Whenever a consumer's utilization equipment has characteristics which cause undue interference with OTEC service to other consumers, the consumer shall make changes in such equipment or provide, at consumer expense, additional equipment to eliminate the interference.

Additional facilities such as separate OTEC transformers and a separate service can be used to minimize voltage fluctuations on secondary-voltage circuits for devices such as welders, induction heating equipment, and X-ray machines. Where practical, OTEC will furnish additional equipment in accordance with the Line Extension Policy.

High-frequency equipment such as electronic heating equipment, spark discharge devices, radio transmitting equipment, variable frequency drives and equipment that generates harmonics, such as an induction furnace, needs to be designed and operated so as not to create disturbances on OTEC's electrical system which might interfere with Rev #6 proper operation of communication, radio television, remote control, or other utilization equipment of other consumers. OTEC requires that all loads comply with IEEE 519. Fault current information can be provided upon request to aid in designing harmonic generation equipment. Loads will be tested to verify compliance. Reduced-voltage starters may be required on all motors.

OTEC will generally furnish information regarding permitted starting currents. The starting currents permitted will depend upon the number of times the motor is started, the size and character of the consumer's load, the design of OTEC's distribution system in the area, and will generally be equivalent to the maximum starting current that, in OTEC's opinion, can be supplied without undue interference with service to other consumers.

The consumer needs to specify equipment so flicker remains within the limits in Table 7.5.1 below. If necessary OTEC will provide system impedances to assist the consumer in specifying equipment. Flicker limit information is representative of one installation; two installations on the same circuit violate the limits.

**Table 7.5.1 – Flicker Limits Related to Motor Starting Loads**

PERCENT FLICKER	MAXIMUM RATE
6.0	2 every 3 hours
4.0	1 every hour
2.5	6 every hour
1.5	1 every minute
1.0	4 every minute
0.5	2 every second

The consumer may multiply the appropriate value in the “percent flicker” column by 1.3 for flicker affecting only their facilities.

## 7.6 POWER FACTOR

OTEC’s rate specifies a charge for excessive reactive requirements. Excessive reactive requirements may cause inferior performance of the consumer’s electrical system and excessive line losses on OTEC’s system. It is recommended that the consumer install corrective devices to make the most effective use of the electrical system.

## 7.7 EMERGENCY OR STANDBY GENERATORS

Permanently installed emergency or standby generators are to be connected to the consumer’s wiring system by a permanently installed (**break before make**) transfer switch intended for that purpose. The transfer switch is to disconnect all ungrounded conductors connected to OTEC system prior to connecting the generator to the conductors supplying the load.

The transfer switch is to be designed and installed so that a connection of the generator to OTEC system is prevented for any mode of operation. Compliance with these provisions is necessary to prevent serious or fatal accidents. Portable generators **SHALL NOT** be connected to a permanent wiring system at any time, unless the interconnection is made with a permanently installed transfer switch.

All transfer switches and/or transfer operating schemes must meet applicable building codes and be inspected by the electrical inspector.

## **7.8 PARALLEL GENERATION**

Parallel generation is the parallel production of electric energy where sources of generation other than OTEC's are connected for parallel operation with OTEC's system. Such sources, when consumer owned, may provide all or a part of a consumer's requirements. Each proposal for parallel generation will be handled on an individual basis and may require a special contract between the consumer and OTEC.

The consumer must provide a lockable disconnect switch with a visible air gap to isolate their generation from OTEC's system. This disconnect switch needs to be accessible to OTEC and OTEC shall have the right to lock the switch open whenever necessary to maintain safe electrical operating conditions.

OTEC must approve operation of the consumer's parallel generation system as well as being inspected by the state electrical inspector. OTEC will also designate metering type and location. Please contact OTEC for additional information on this topic.

## **7.9 COGENERATION**

Cogeneration is the joint production of electrical energy and useful thermal energy in a combined process. It includes, but is not limited to gas turbines and diesel-driven generators (with waste heat recovery) and steam or back-pressure turbines.

Each proposal for cogeneration will be handled on an individual basis by means of a special contract between the consumer and OTEC.

OTEC must approve operation of the consumer's cogeneration system. OTEC will also designate metering type and location, and the method of interconnection between the consumer system and OTEC.

Please contact OTEC for additional information on this topic.

Approval by OTEC does not warranty the performance of the consumer's facilities.

## **7.10 NET METERING**

Net metering is a debit and credit metering process in an account in which the consumer owns and operates qualified generating device that interconnects with OTEC's electrical facilities. Contact OTEC for interconnection requirements and an application prior to acquiring equipment.

Local and/or other applicable inspection authorities must approve the net metering design prior to installation, and must approve the installation of the consumer's parallel generation system prior to energizing.

**NOTE:** Installation of an automatic parallel generation disconnect safety switch is required on all Net metering installations.

**NOTE:** For Non-CT Metered services removal of the meter maybe used in place of a manual disconnect isolation switch for inverter-based facility for services of 600 volts or less with a maximum rating of 30 amps and generation as follows:

Service Type – Maximum net metering facility size (kW):

- 240 Volts, single-phase, 3 Wire – 7.2 Kw
- 120/208 Volts, 3-phase, 4 Wire – 10.5 kW
- 120/240 Volts, 3-phase 4 Wire – 12.5 kW
- 277/480, 3-phase 4 wire – 25.0 kW

For other service types, the net metering facility must not impact the member-generator's service conductors by more than 30 amperes. If a disconnect switch is installed, member-generator to provide a simple one-line diagram that shows the location of the disconnect switch.

“Parallel Generation Onsite” metal or plastic engrave signage posted as required by the latest edition of the National Electric Code Section 110.22 and 430.102.

**NOTE:** Generation shall not be connected to OTEC's electrical distribution system until written notification authorizing net metering system activation is given by OTEC.

## **7.11 AVAILABLE FAULT CURRENT**

Upon request, OTEC will supply the information on available fault current at the consumer's service entrance. It is the consumer's responsibility to furnish equipment which will withstand that fault current.

## **VIII. OTHER CONSUMER RESPONSIBILITIES**

### **8.1 CONSUMER'S RESPONSIBILITY FOR SAFETY**

The consumer shall comply with all federal, state, and local laws and regulations as well as all applicable laws of negligence concerning all activities in the vicinity of OTEC's electrical wire lines and equipment, whether on consumer premises or used to deliver electricity from the generating facilities to the premises. The consumer shall comply with laws and regulations to protect themselves, OTEC, and all other parties from injury, loss, or damage. If OTEC serves the consumer by means of primary-voltage or transmission voltage circuits on the consumer's premises, OTEC may require the consumer to obtain and retain insurance coverage which OTEC deems adequate to satisfy the duty of indemnification.

### **8.2 RIGHTS-OF-WAY**

The consumer shall provide, without cost to OTEC, all rights-of-way and easements where required for the installation of facilities necessary or convenient for the supplying of electrical service and free access to consumer's premises for all work necessary to maintain continuity of such service.

### **8.3 TREES AND SHRUBS**

The consumer shall prepare the premises so that trees, shrubs, and other vegetation will not interfere with the proper operation and maintenance of OTEC facilities. Consult OTEC for clearance requirements of your specific installation.

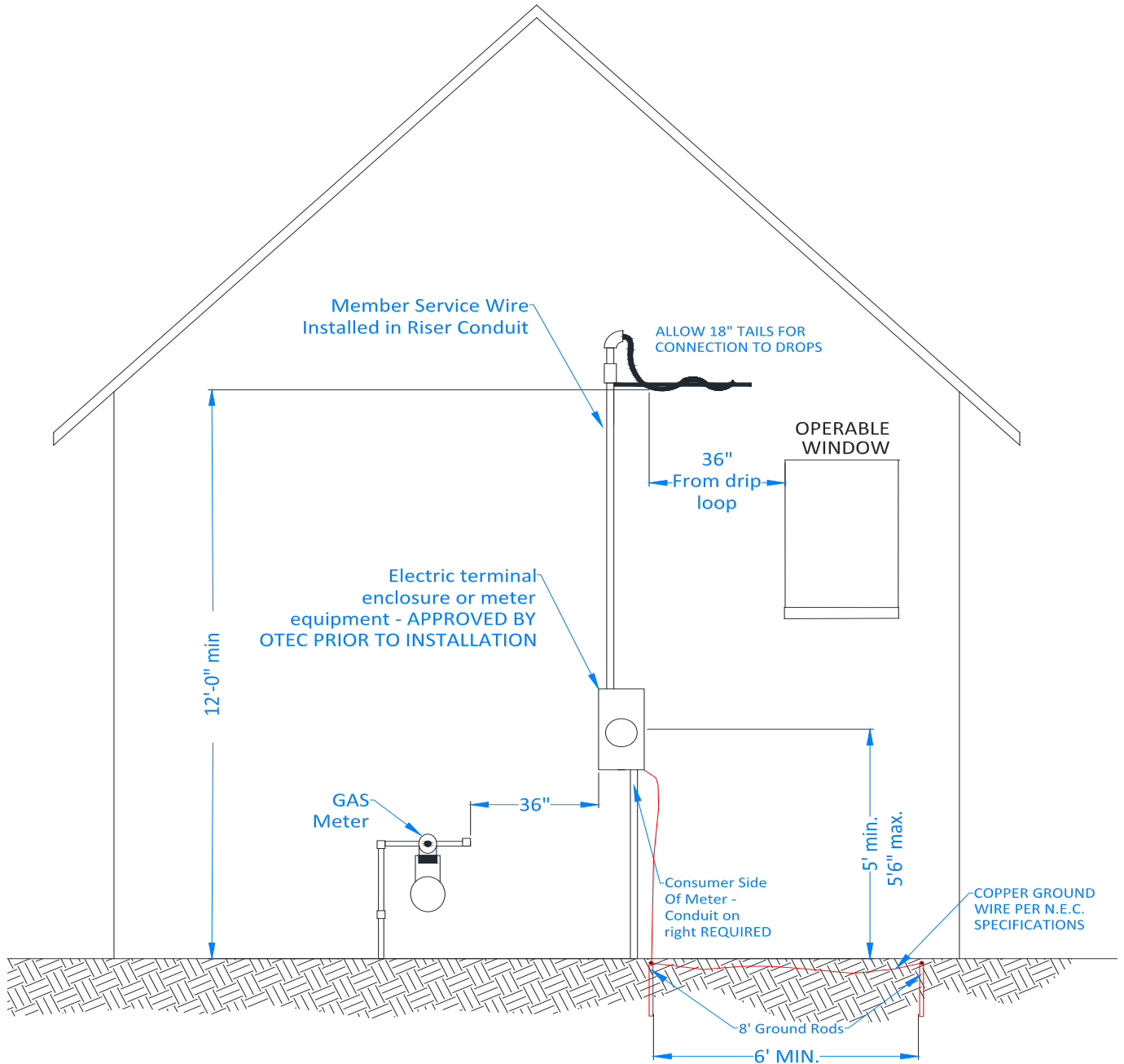
### **8.4 CALL BEFORE YOU DIG**

State law requires the consumer/excavator to call for underground utility cable locations at least two full working days (48 hours) prior to excavation. The excavation must not be started until locations have been marked or the utilities have informed the excavator that they have no facilities in the area. **Call 811 or 1-800-332-2344 before you dig.**

# IX. TYPICAL INSTALLATION DRAWINGS AND REQUIREMENTS

## 9.1 RESIDENTIAL OVERHEAD SERVICE

Figure 9.1.1 – Residential Overhead Service Meter Base Clearance Requirements<sup>6</sup>



<sup>6</sup> Refer to Figures 9.3.1 and 9.4.1 for Mast Install Details.

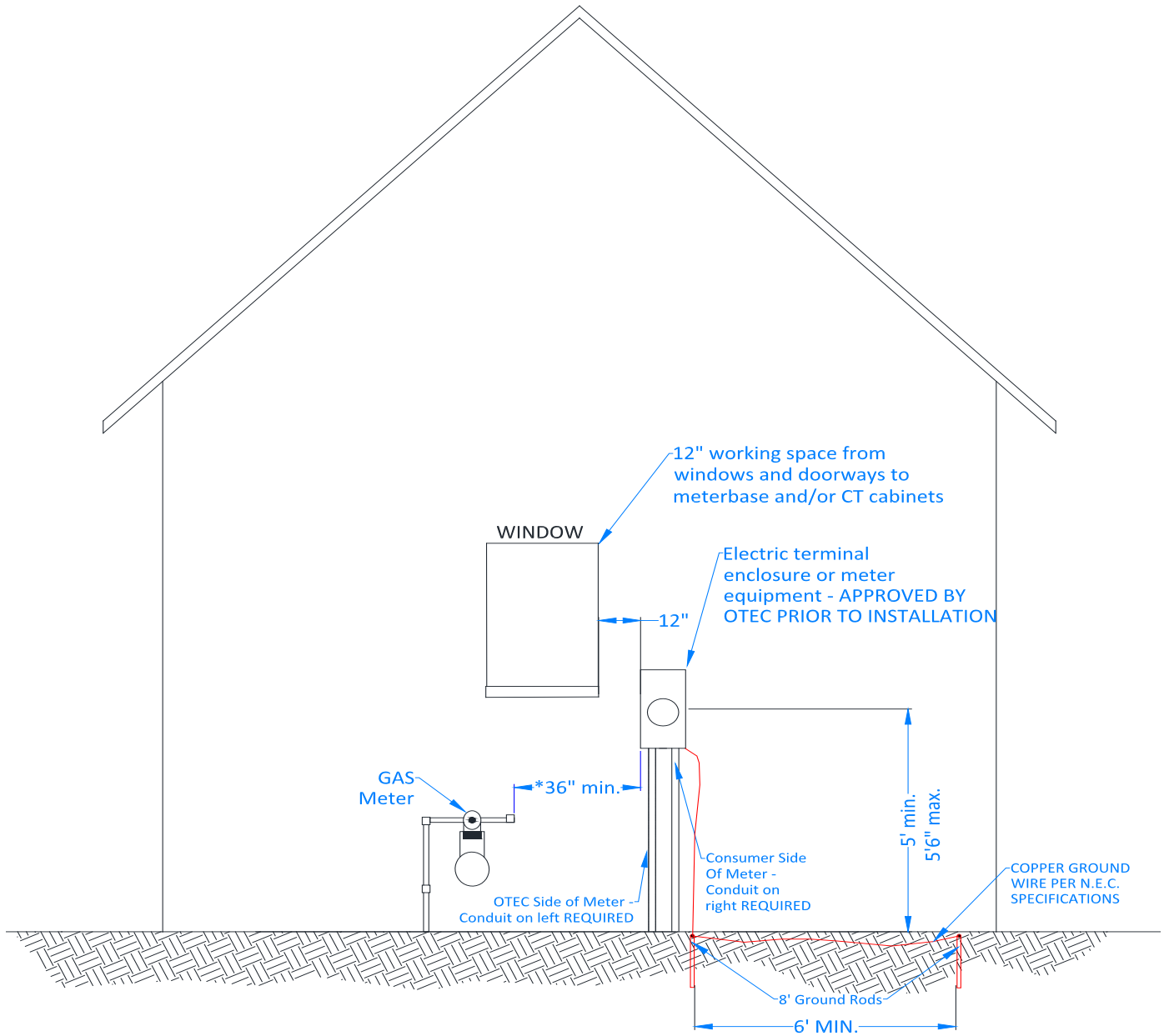
1. Meter location must be approved by OTEC prior to installation (see Section 2.5)
2. The service entrance needs to be located so that the open conductors are a minimum of 12 feet above finished grade, or from any platform or projection from which they may be reached<sup>8</sup>.
3. The service conductor needs to be at least 3.5 feet above an inaccessible roof (11 feet over an accessible roof). If not more than 6 feet of service drop overhangs the roof and weather-head is within 4 feet of the edge of the roof; 1.5 feet above the roof is allowed.
4. Service conductor drops must meet the following minimum clearance requirements: 12 feet above finished grade, 12 feet over residential driveways, and 16 feet over streets (see Section 3.3)<sup>7</sup>.
5. Height of meter from ground line, 5 feet-0 inches minimum to 5 feet-6 inches maximum.
6. See Figures 9.3.1 and 9.4.1 for weather-head extending through roof.
7. The consumer must install overcurrent (OC) main breaker protection adjacent to the meter.
8. Overhead service drip loop is to be not less than 3 feet in any direction from windows.
  - a. Exception 1: This does not apply to service voltage rated conductors above the top level of a window.
  - b. Exception 2: This does not apply to windows that are not designed to open.

---

<sup>7</sup> Clearances are based on current National Electrical Safety Code.

## 9.2 ELECTRICAL METER BASE CLEARANCE REQUIREMENTS

Figure 9.2.1 – Underground Residential Service Meter Base Clearance Requirements

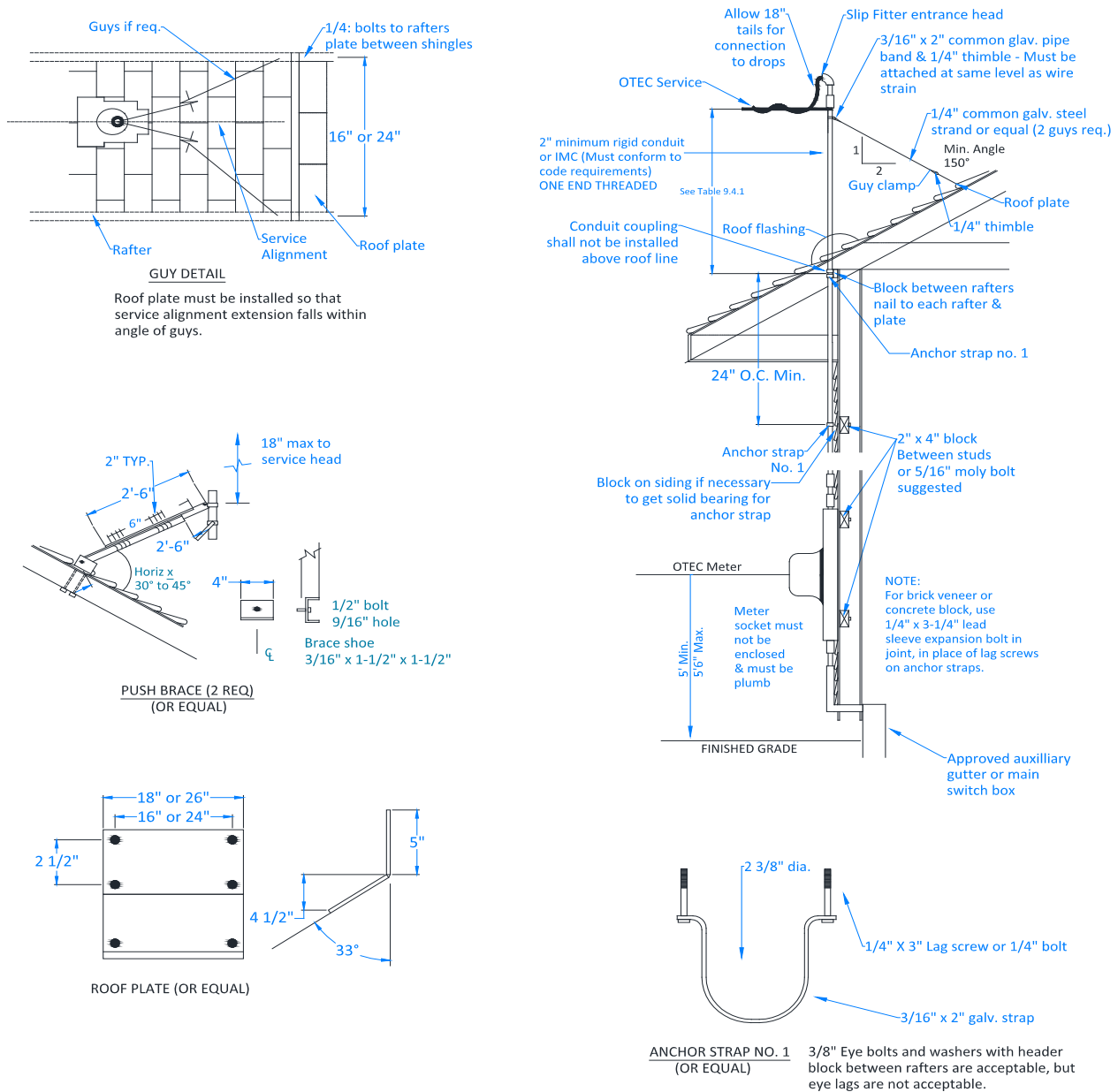


**Attention: Minimum 12 inches of clear working space required between electric meter/CT cabinets, windows and doorways, 36" between electric meter/CT cabinets and gas meter.**



### 9.3 SUGGESTED METHOD OF INSTALLING OVERHEAD SERVICE WHEN GUYING IS REQUIRED

**Figure 9.3.1 - Single-Phase Self-Contained Metering - Exterior Method**

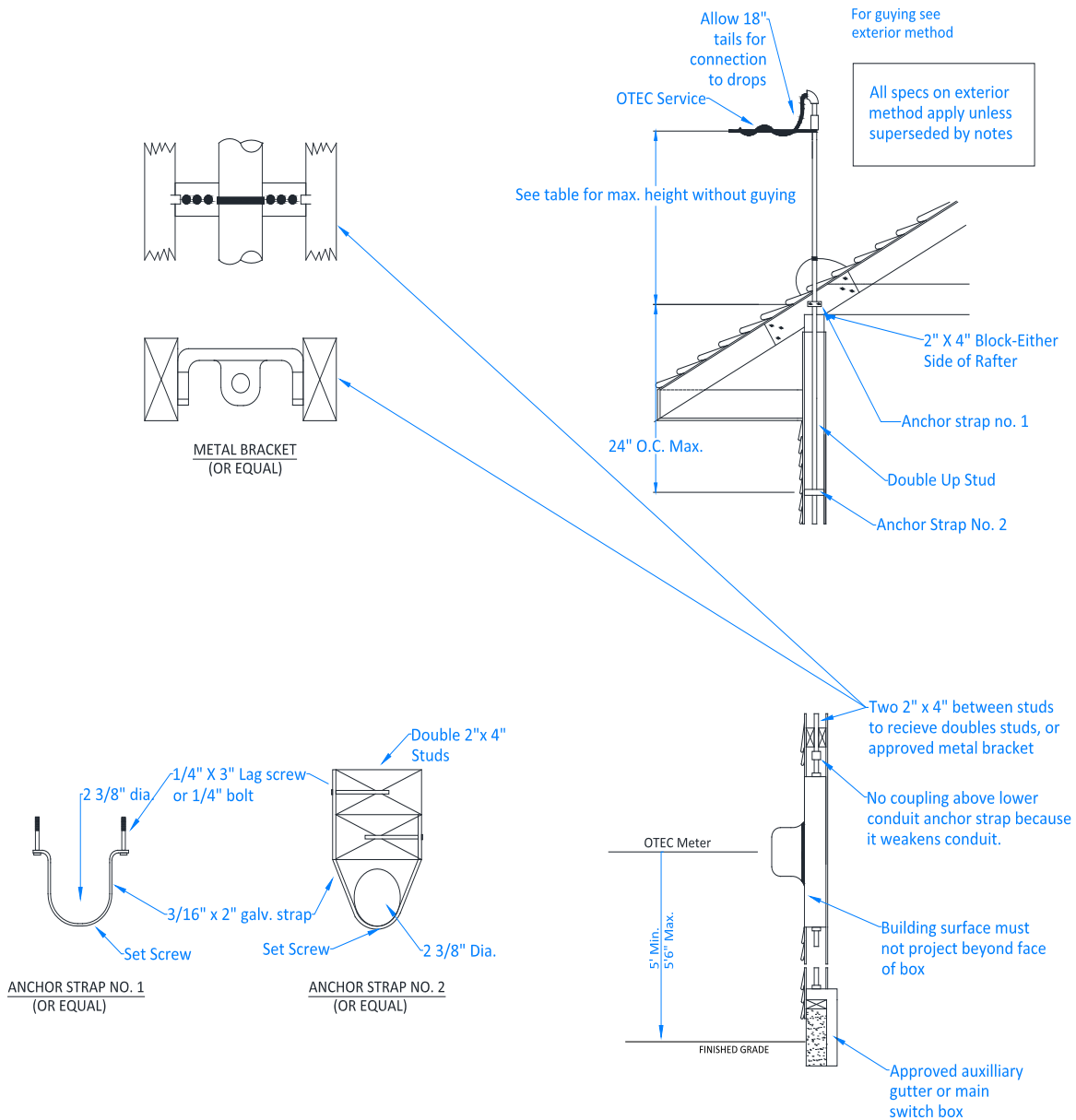


Attention: Service mast must be mounted on side nearest distribution pole. Consult OTEC for rear of lot utility lines. Avoid service wire overhanging roof or provide required clearance over roof. Service entrance must be rigidly secured. All ferrous hardware to be hot dip galvanized.

See Table 9.4.1 on following page for guying requirements.

## 9.4 SUGGESTED METHOD OF INSTALLING OVERHEAD SERVICE

### Figure 9.4.1 - Single-Phase Self-Contained Recessed Metering Method



Attention: Service mast must be mounted on side nearest distribution pole. Consult OTEC for rear of lot utility lines. Avoid service wire overhanging roof, or provide required clearance over roof. Service entrance must be rigidly secured.

### Table 9.4.1 – Service Entrance Maximum Height without Guying

METER SERVICE SIZE	UTILITY SERVICE LENGTH	LENGTH OF UNSUPPORTED MAST
200 Amp Service - 2 Inch Conduit	80 Feet	36 Inches
320 Amp Service - 2 Inch Conduit	60 Feet	36 Inches

## 9.5 OVERHEAD SERVICE DETAILS – MULTIPLE OCCUPANCY BUILDINGS

Figure 9.5.1 - Grouped Meters – Single Service Mast<sup>8</sup>

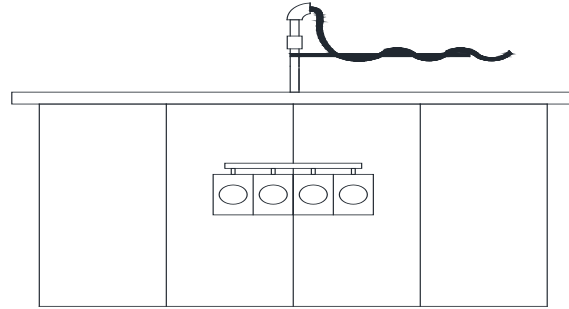


Figure 9.5.2 - Grouped Meters – Individual Service Masts<sup>9</sup>

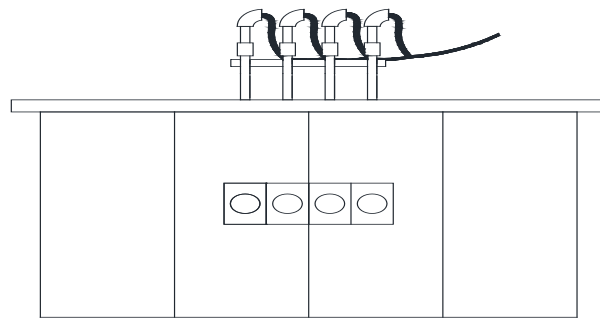
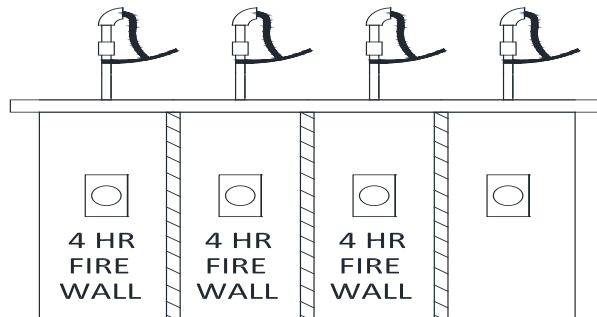


Figure 9.5.3 – Individual Meters – Individual Utility Service<sup>10</sup>



### **NOTES:**

1. Service mast(s) need to be mounted on side nearest OTEC distribution pole. Avoid overhang of roof or provide required clearance over roof (see Section 3.3 for clearances or refer to currently approved edition of the National Electric Safety Code).
2. Guying of service masts may be required (see Page 47, Figure 9.3.1 and Page 48, Figure 9.4.1 for guying requirements).

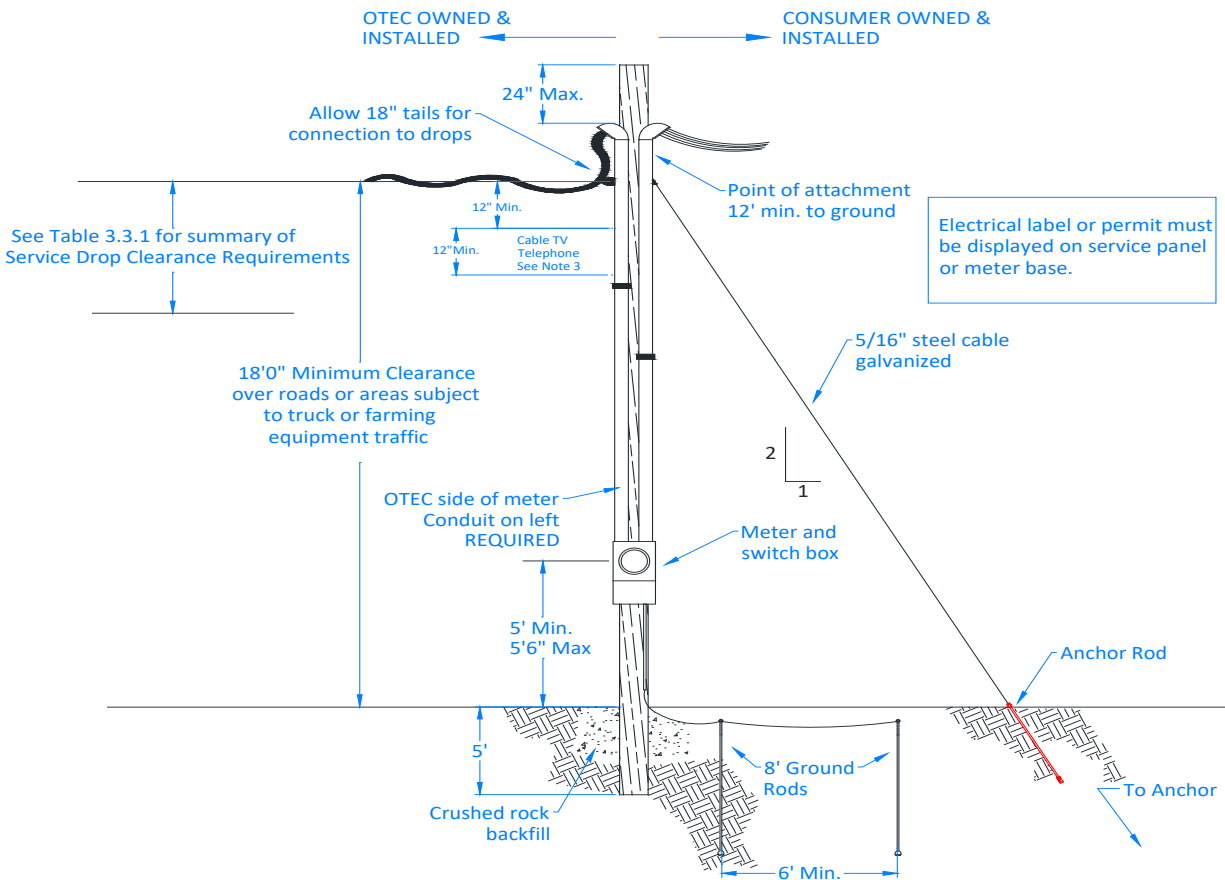
<sup>8</sup> A sealable service gutter is required by this arrangement.

<sup>9</sup> Individual service masts must be arranged so all service entrance tails will reach a single point of attachment on the OTEC service.

<sup>10</sup> Requires firewalls between occupancies as shown. This arrangement must have prior approval of electrical inspection authority and OTEC.

## 9.6 OVERHEAD SERVICE FOR POLE MOUNTED INSTALLATION

Figure 9.6.1 – Overhead Service – Pole Mounted Installation

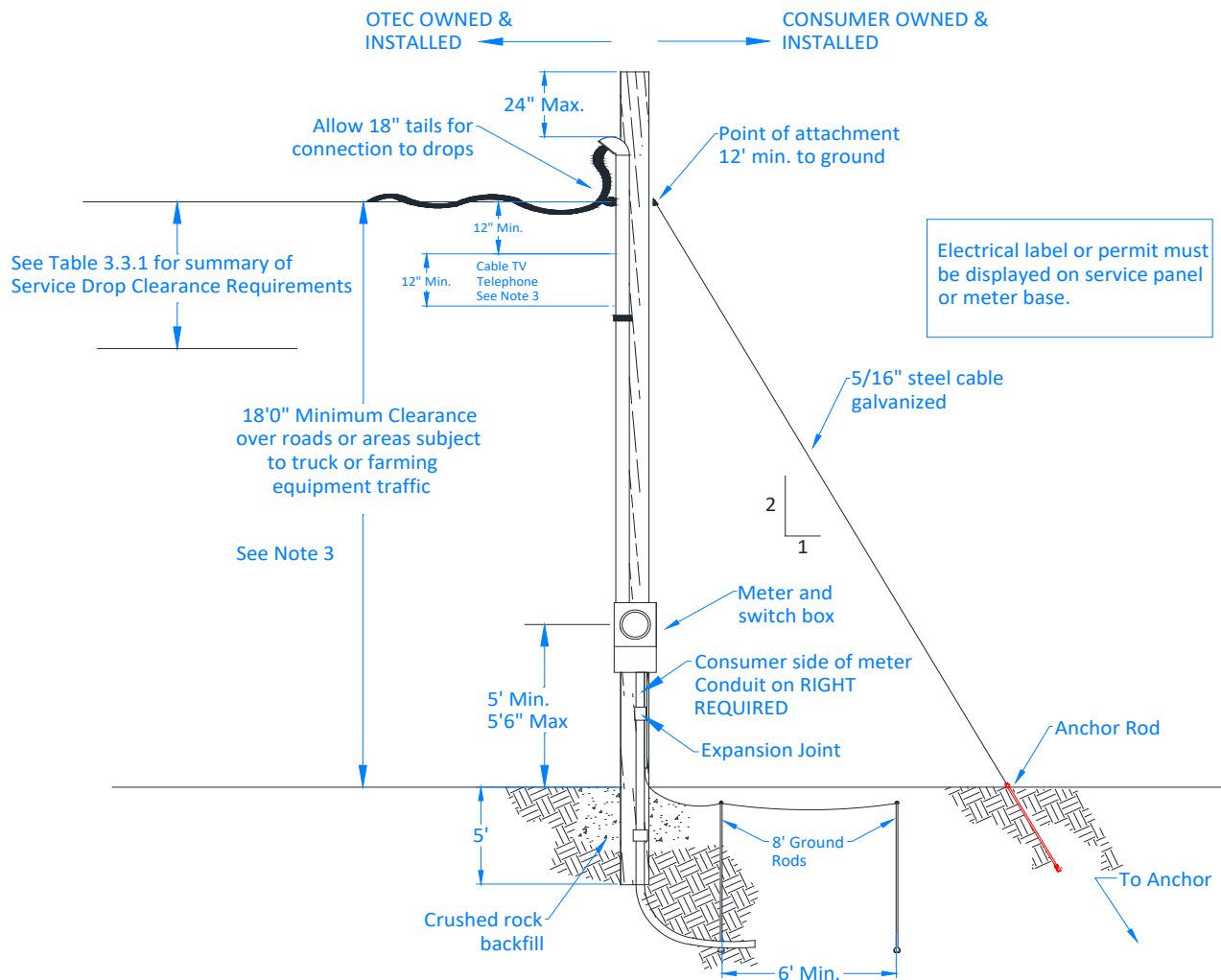


### NOTES:

1. Consumer to provide guying if required by utility. Guy may be attached to pole with a threaded eyebolt and washer assembly. Screw in type attachments are not acceptable. Attachment is to be within 12 inches of utility attachment but must have minimum 3 inch of metal to metal separation.
2. Pole required minimum length of 25 feet. Class 6 (5 ½ inch top diameter, 7 ½ inch minimum diameter 6 feet from butt) pressure or thermally treated, set no less than 5 feet below ground level. Use crushed rock backfill if soil is unstable. Pole to be 30 feet minimum length if service drop crosses a road or traffic area.
3. Additional height may be required to accommodate overhead telephone service or cable TV. Contact OTEC for required clearance.
4. Electrical label or permit needs to be displayed on service panel or meter base.
5. The consumer must install overcurrent main breaker protection adjacent to the meter.

## 9.7 OVERHEAD SERVICE FOR UNDERGROUND SERVICE LATERAL

Figure 9.7.1 – Overhead Service to Underground Consumer Side

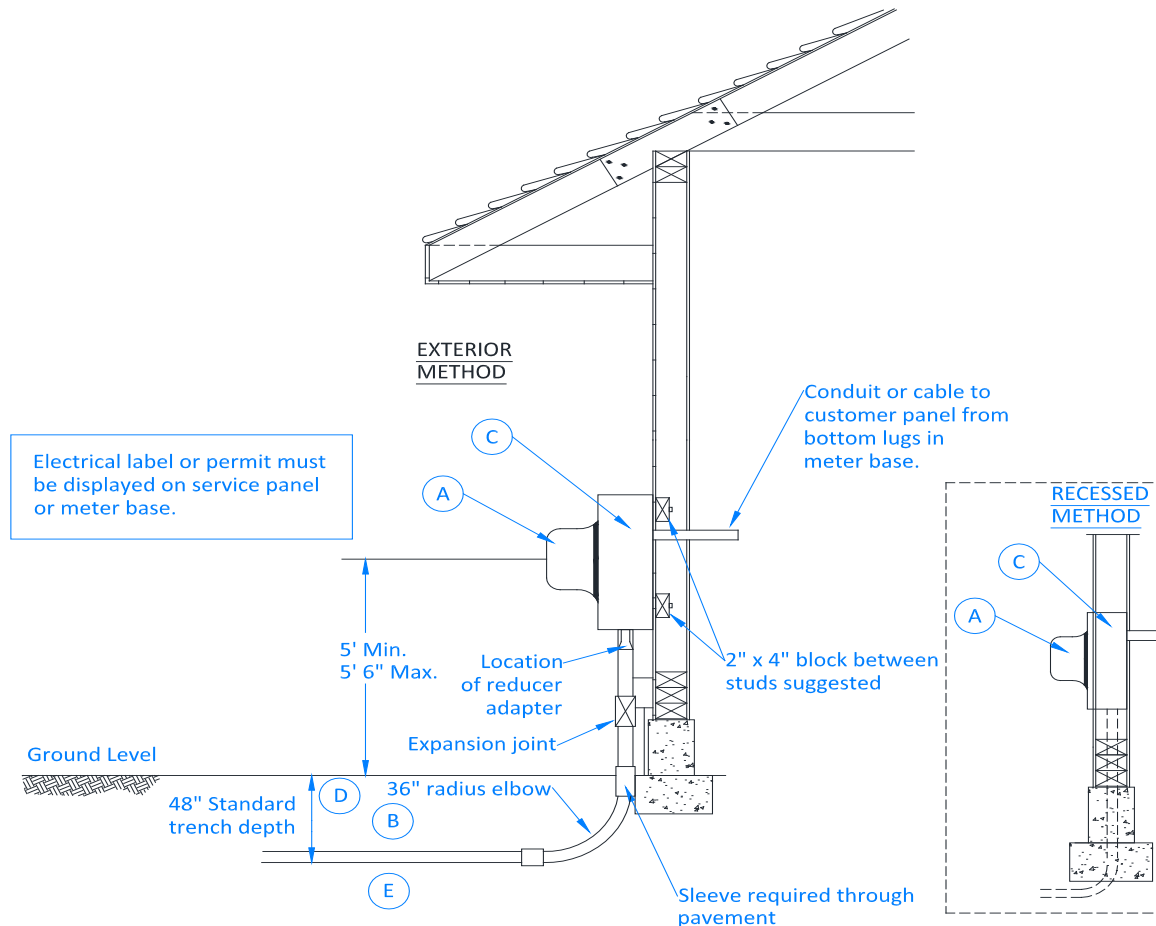


### NOTES:

1. Consumer to provide guying if required by utility. Guy may be attached to pole with a threaded eyebolt and washer assembly. Screw in type attachments are not acceptable. Attachment is to be within 12 inches of utility attachment but must have minimum 3 inches of metal to metal separation.
2. Pole required minimum length of 25 feet. Class 6 (5 ½ inch top diameter, 7 ½ inch minimum diameter 6 feet from butt), pressure or thermally treated, set no less than 5 feet below ground level. Use crushed rock backfill if soil is unstable. Pole to be 30 feet minimum length if service drop crosses a road or traffic area.
3. Additional height may be required to accommodate overhead telephone service or cable TV. Contact OTEC for required clearance.
4. Electrical label or permit needs to be displayed on service panel or meter base.
5. The consumer needs to install overcurrent protection adjacent to the meter.

## 9.8 SUGGESTED METHOD OF INSTALLING UNDERGROUND SERVICE SELF-CONTAINED METERING<sup>11</sup>

Figure 9.8.1 – Installation of Underground Service – Self-Contained Metering



### NOTES:

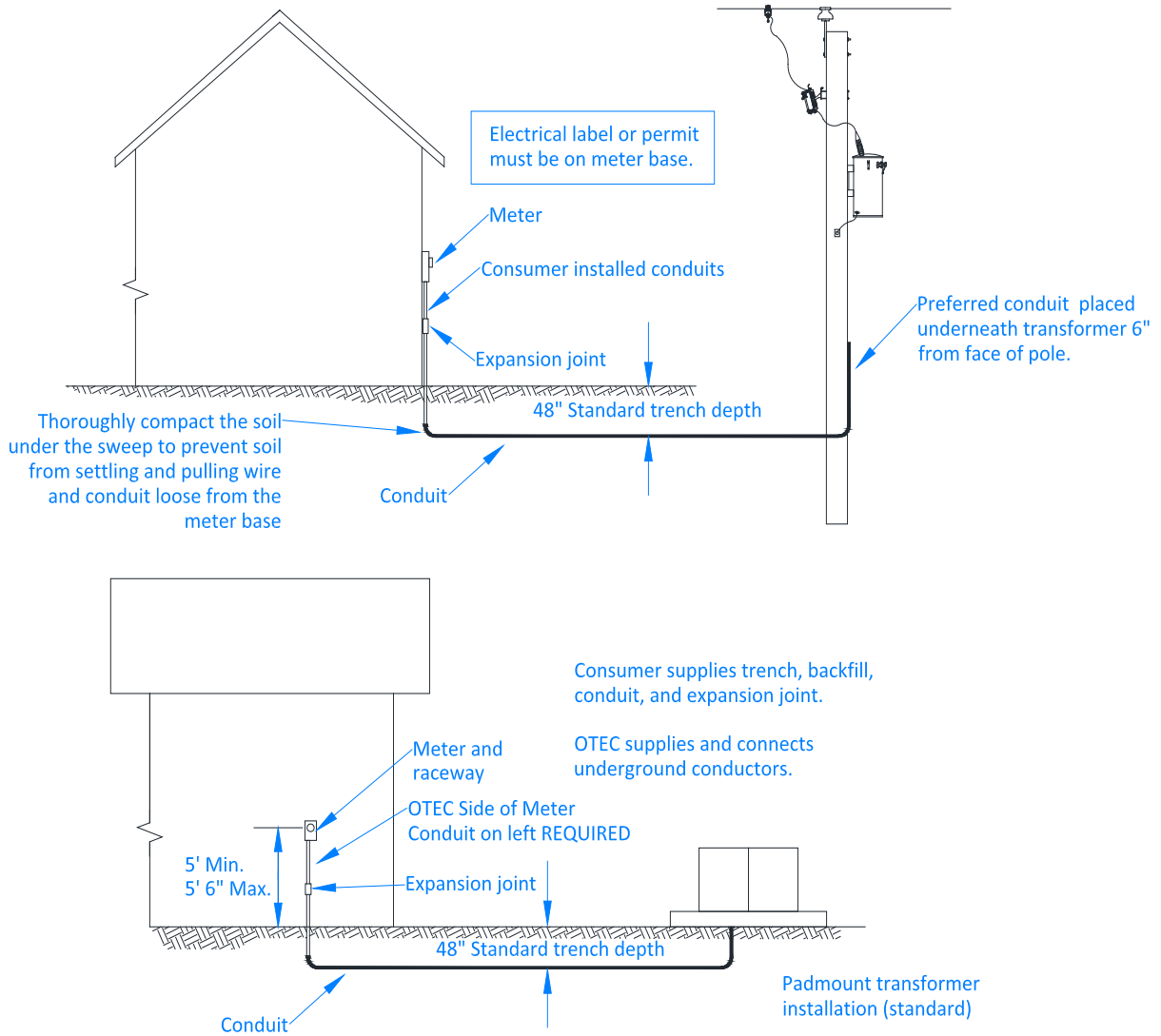
1. Electrical label or permit needs to be displayed on service panel or meter base.
2. Meter base and conduit needs to be securely attached to structure. Consumer provides conduit and expansion joint. Overcurrent protection needs to be installed adjacent to the meter.
3. Socket needs to be plumb and switch box needs to be covered when inspected.
4. For 200 amp or smaller services, OTEC will terminate the service lateral on the line-side terminals of the consumer's meter socket, provided the consumer's conduit is a minimum of 2 inches for single-phase and 3 inches for three-phase, the meter socket enclosure has a minimum dimension of 11x 14 x 4-1/8 inches, and the line-side meter socket lugs will accept 1/0 -4/0 KCM aluminum conductor.

<sup>11</sup> OTEC will furnish: A) Meter B) Service Wire. Consumer will furnish: C) Meter Base, Ring, and Expansion Joint D) Trench, Backfill, and Conduit. Contact OTEC for trenching requirements. E) Right-of-Way

5. For single-phase greater than 200 through 400 amp service, a continuous-rated meter socket is normally required for code-calculated loads not exceeding 320 amps. OTEC will terminate the service lateral on the line side of the meter socket provided the consumer's conduit is a minimum of 3 inches in diameter, the meter socket enclosure has minimum dimensions of 13 x 22 x 4 ½ inches, and line-side meter socket lugs will accept 1/0 - 350 KCM conductor (see Section 6.3 - Note 2).
6. Meter base must have 36 inches required working space to gas meter.

## 9.9 UNDERGROUND SERVICE

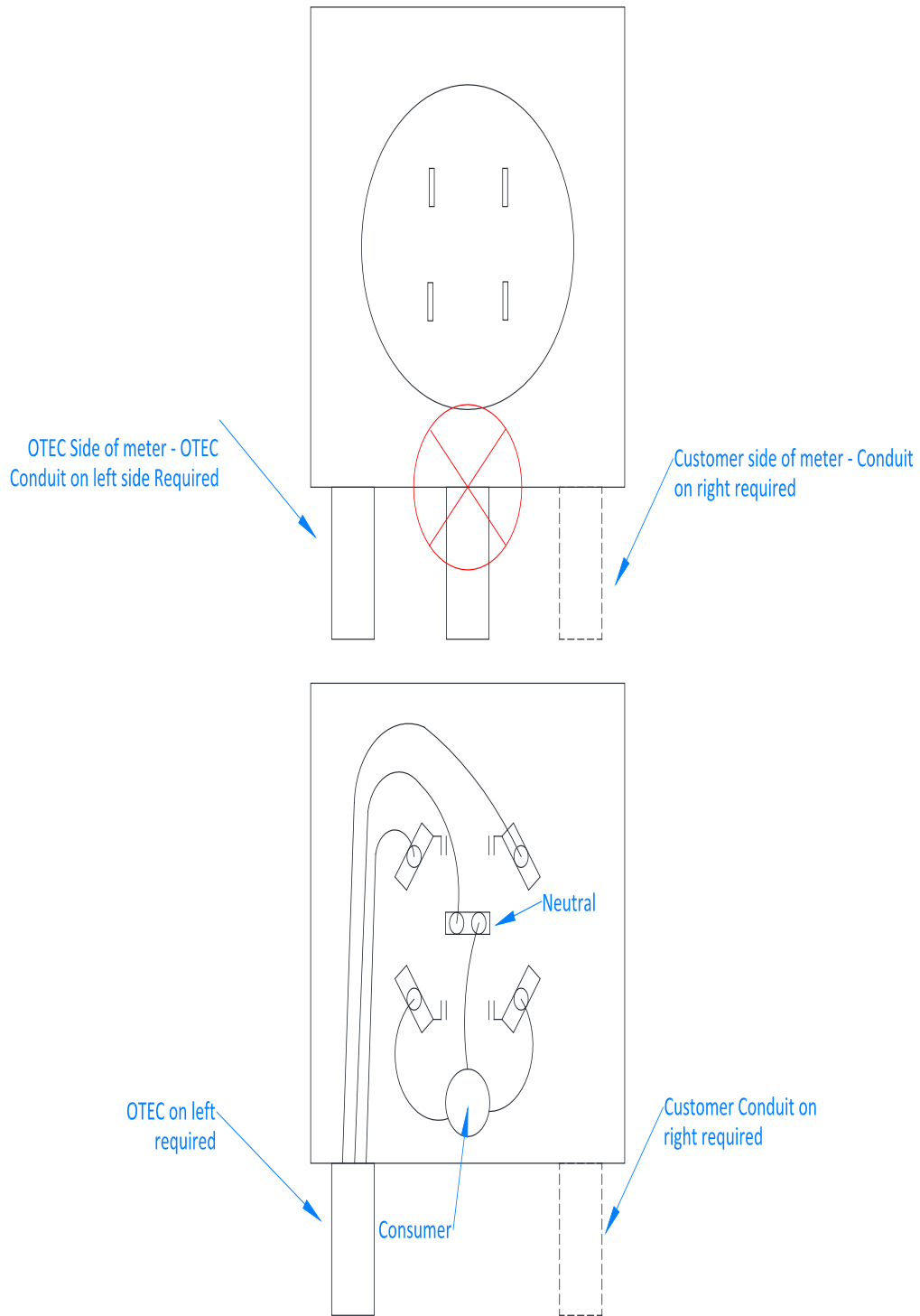
**Figure 9.9.1 – Service Detail – Single-Family Dwelling**



Attention: Conduit is required to protect the conductor from rock, rodents, and other conditions. Consult OTEC for conduit placement prior to trenching.

**Figure 9.9.2 – Meter Socket Detail – Single Family Dwelling**

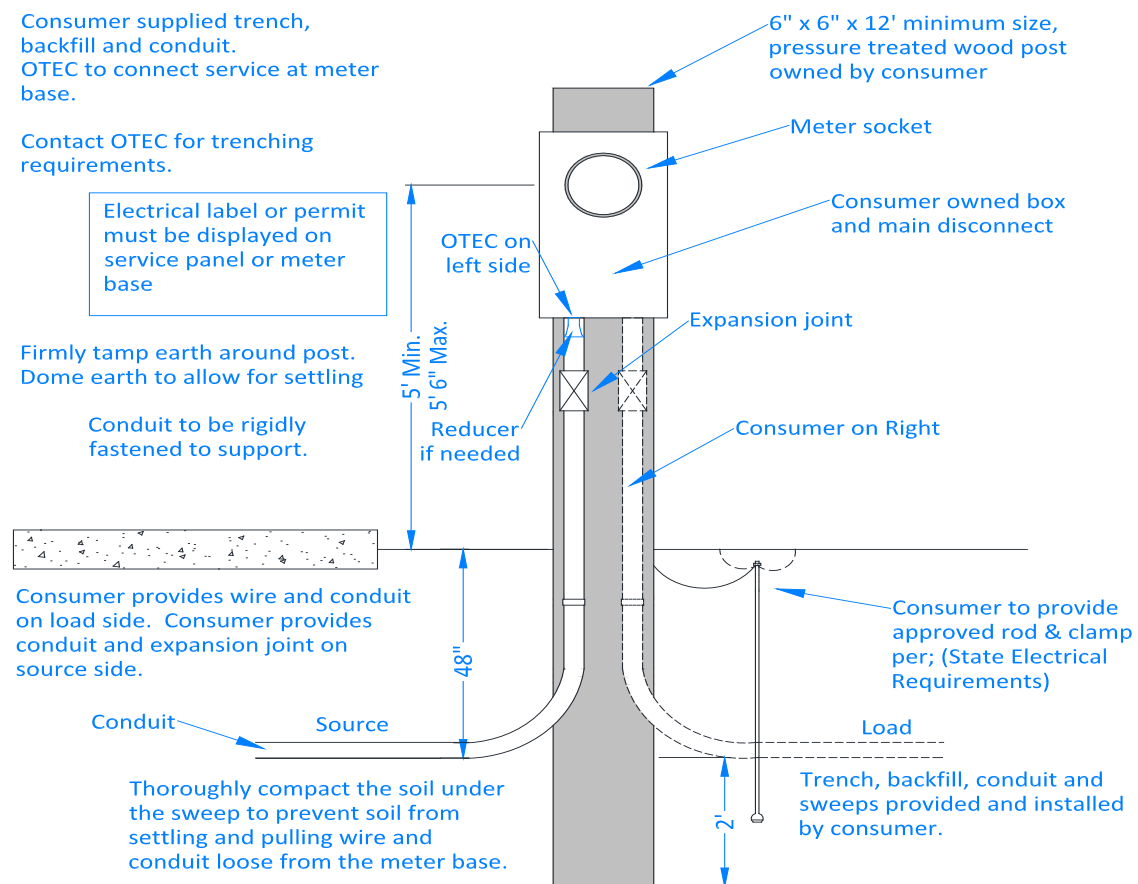




Attention: OTEC Conduit should enter on the left side NOT IN THE MIDDLE of the meter base to avoid obstruction with consumer's conductor.

## 9.10 UNDERGROUND SERVICE FOR MANUFACTURED HOME

Figure 9.10.1 - POST-MOUNTED INSTALLATIONS



### **NOTES:**

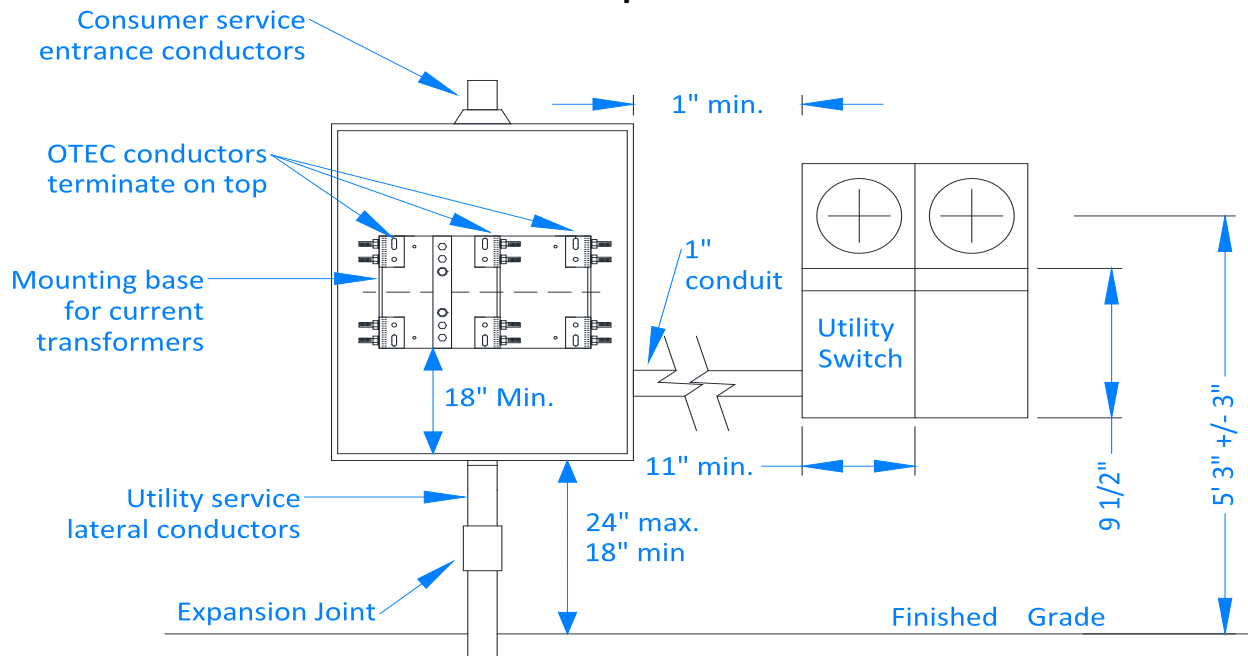
1. Electrical label or permit needs to be displayed on service panel or meter base.
2. Meter base and conduit needs to be securely attached to structure. Consumer provides conduit and expansion joint. Overcurrent protection needs to be installed adjacent to the meter.
3. Socket needs to be plumb and switch box needs to be covered when inspected.
4. For 200 amp or smaller services. OTEC will terminate the service lateral on the line-side terminals of the consumer's meter socket, provided the consumer's conduit is a minimum of 3 inches for three-phase, (consult OTEC for conduit size requirements for single phase), the meter socket enclosure has a minimum dimension of 11x 14 x 4-1/8 inches, and the line-side meter socket lugs will accept 1/0 -4/0 KCM aluminum conductor.

5. For single-phase greater than 200 through 400 amp service, a continuous-rated meter socket is normally required for code-calculated loads not exceeding 320 amps. OTEC will terminate the service lateral on the line side of the meter socket provided the consumer's conduit is a minimum of 3 inches in diameter, the meter socket enclosure has minimum dimensions of 13 x 22 x 4 ½ inches and line-side meter socket lugs will accept 1/0 - 350KCM conductor. Unmetered wires between utility connections and top side of meter base need to be accessible only to OTEC.



## 9.11 THREE-PHASE CURRENT TRANSFORMER METERING

**Figure 9.11.1 - Service Below 600V, Three-Phase Over 200 Amps Up To/Including 800 Amps<sup>12</sup>**



### **NOTES:**

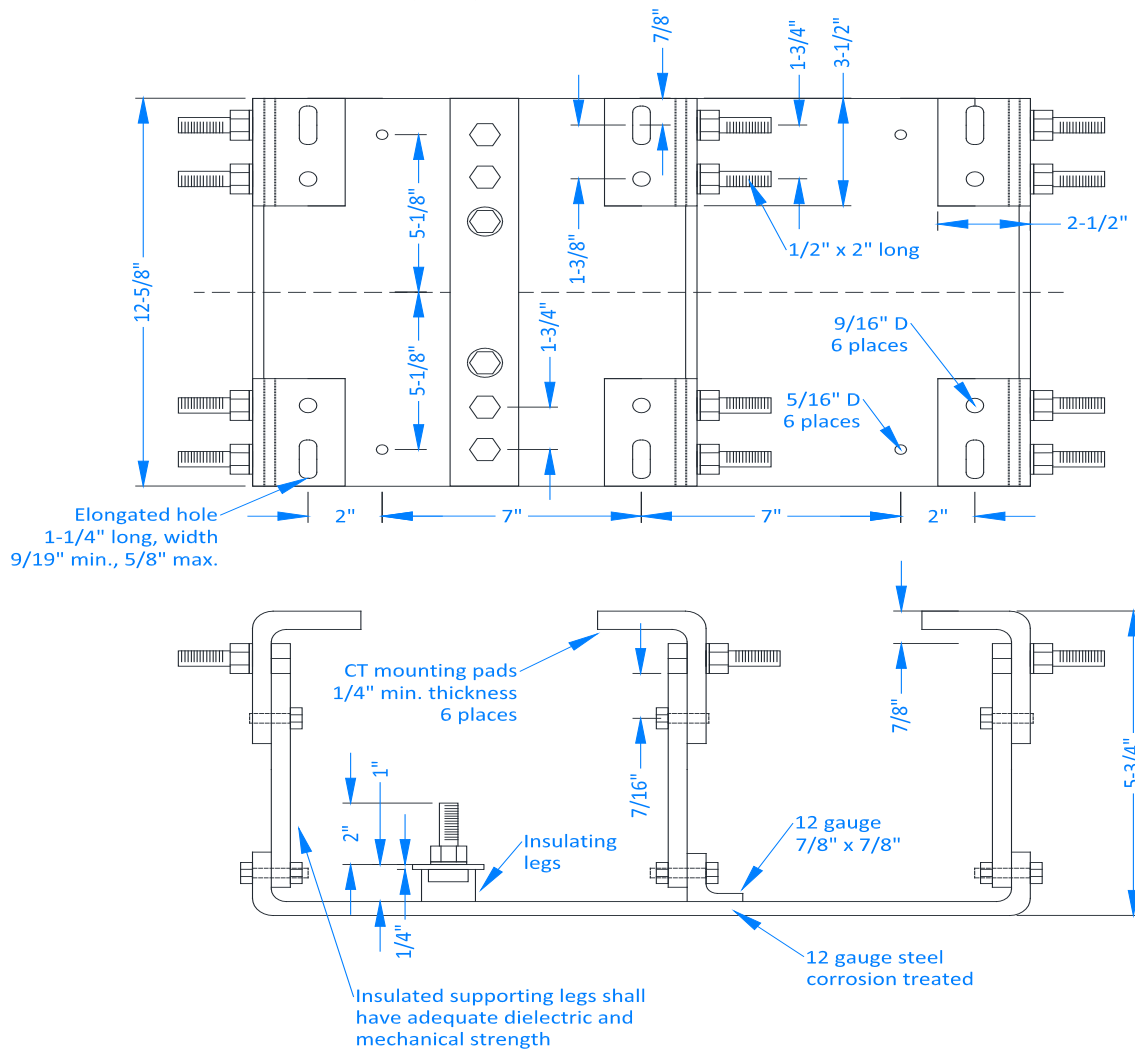
1. A current transformer (CT) enclosure may be used as a combination CT and OTEC underground serviced terminating pull box. Consumer's conductors will not be permitted in OTEC terminating and pull space portion of the box. For all other underground service applications, a separate terminating pull box will be provided for OTEC service lateral. Consult OTEC for terminating pull box requirements.
2. Only conductors associated with metering or grounding are permitted in the CT enclosure. No connections are to be made in any CT enclosure to supply any other meter.
3. Consumer to provide approved connectors for connecting consumer conductors to the CTs. Bolts need to be provided with nuts, flat washers, and a pressure-maintaining spring washer. All parts need to be compatible with the bus-bar and connectors (Everdur or stainless steel).
4. OTEC will mount CTs
5. CT enclosure covers need to be sealable and may be either one piece hinged with a hold open mechanism, or one piece removable with handles. A two-piece door is acceptable if can is 14 inches deep and doors have handles.

<sup>12</sup> Minimum Cabinet Size for three-phase service with service entrance capacity greater than 200 amps and up to/including 800 amps: 48 X 48 X 14 inches.

6. Metallic conduit for meter leads to be minimum of 1 inch and limited to a run of 50 feet or less with not over 270 degrees in bends. Only OTEC conductors will be permitted in metering conduit.
7. Cabinet needs to be rain-tight.
8. CT enclosure is to be mounted outside and accessible. Where CTs or other equipment is installed in a location where it might be struck by a motorized vehicle, OTEC may install or require consumer to install barrier post to protect equipment (see Page 65, Figure 9.16.1).

## 9.12 TRANSFORMER MOUNTING BASE FOR INSTALLATION IN CURRENT TRANSFORMER ENCLOSURE

**Figure 9.12.1 - 600V, Three-phase, Three-Wire or Four-Wire, Wye or Delta Service Greater than 200 Amps Up To/Including 800 Amps<sup>13</sup>**



**Table 9.12.1 – CT Mounting Bus**

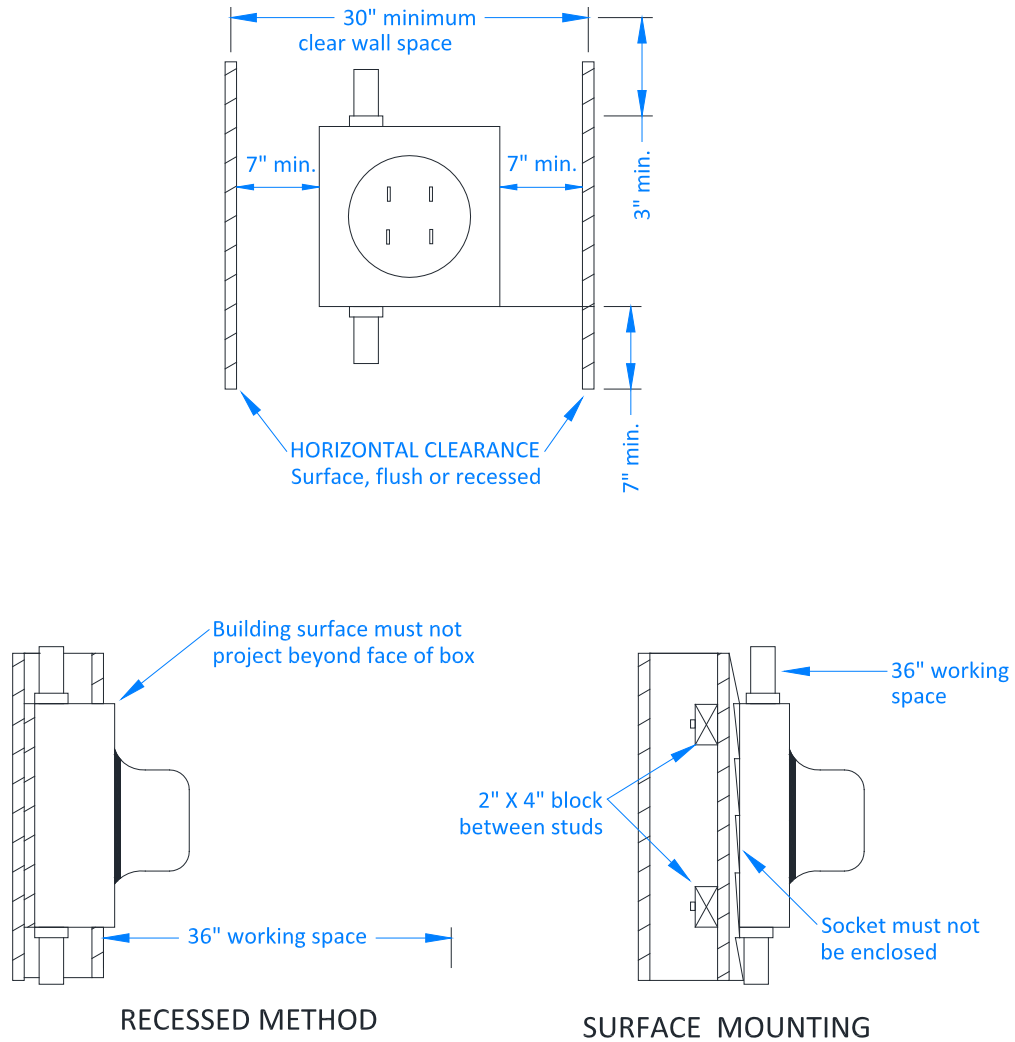
Catalog Number	AIC Rating	#of C.T. Provisions	Ampacity		Voltage	Service Type	Line	Lug Wire Range Load
			Max.	Cont.				
6067 Heels	50K	3	800	800	600	30 4W	Studs	(3) 4 AWG - 600kcmil or (6) 1/0- 250kcmil

**Attention:** This bus must meet the ampacity requirements of the NEC.

<sup>13</sup> For use with CT rated metering enclosures. For use with bar-type CT that meets ANSI C 12.11. Studs line side – lugs load side. 1/2 inch studs on 1-3/4 inch centers.

## 9.13 METER SOCKET CLEARANCE REQUIREMENTS

Figure 9.13.1 – Meter Socket Clearance Requirements

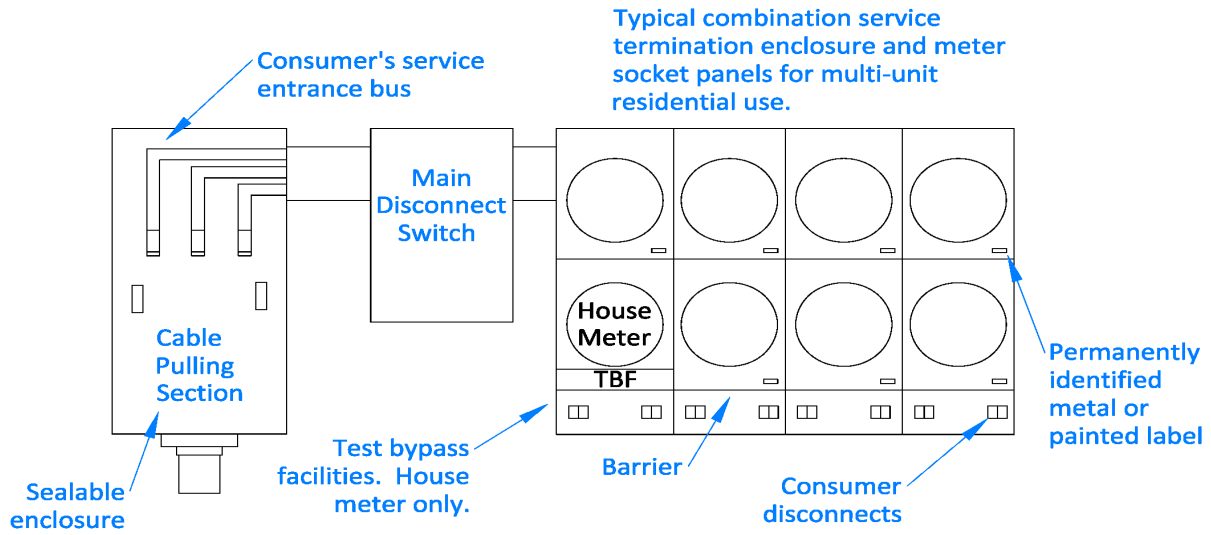


Attention: See Page 11, Section 2.5 and Page 31, Section 6.4 for written location and mounting requirements.

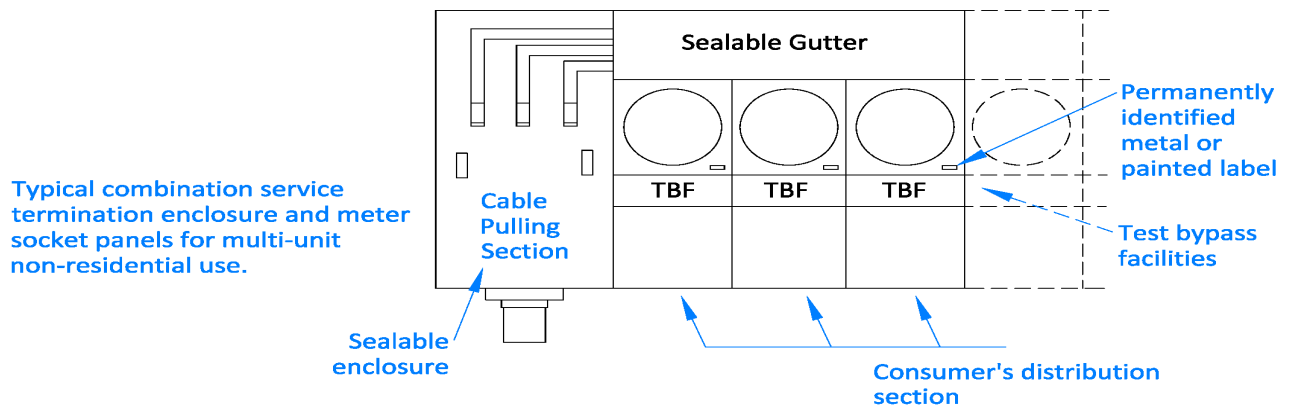


## 9.14 MULTIPLE METER SOCKET INSTALLATIONS

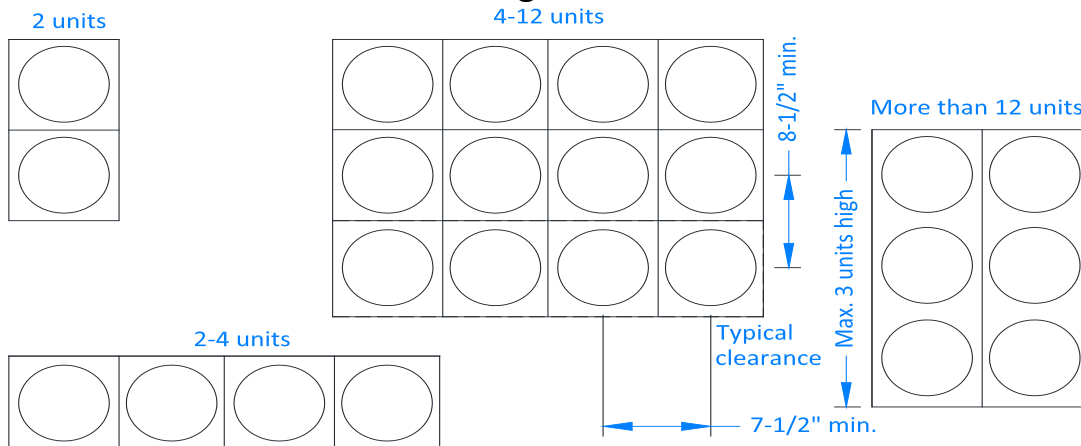
**Figure 9.14.1 – Multiple Meter Socket Installation – Residential Configuration**



**Figure 9.14.2 – Multiple Meter Socket Installation - Non-Residential Configuration**

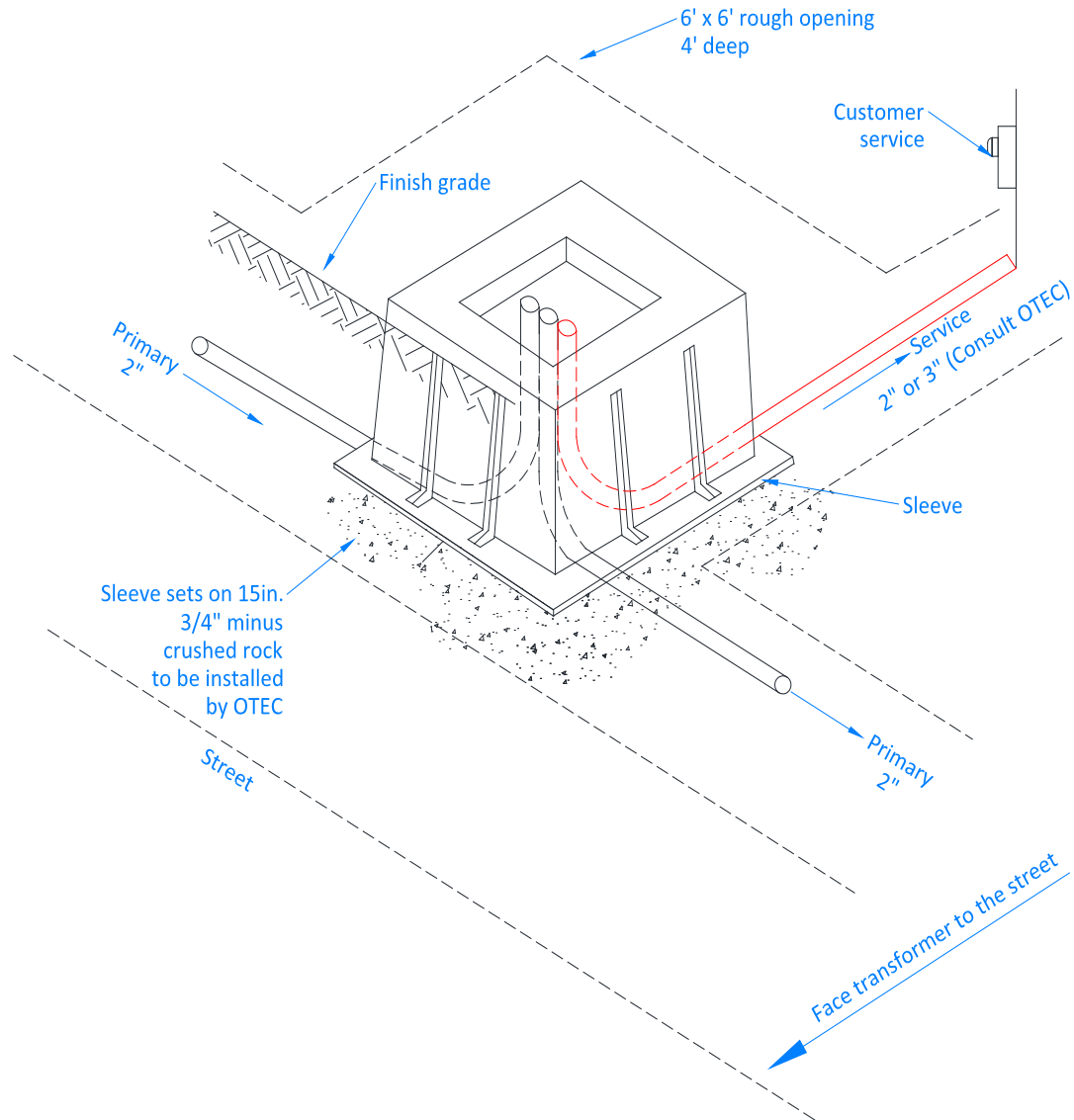


**Figure 9.14.3 – Acceptable Multiple Meter Socket Installations - Miscellaneous Configurations**



## 9.15 FIBERGLASS GROUND SLEEVE INSTALLATION

Figure 9.15.1 – Fiberglass Ground Sleeve Installation



Attention: Stub outs should be a minimum 10 feet beyond edge of sleeve and ends marked with fiberglass underground marker posts.

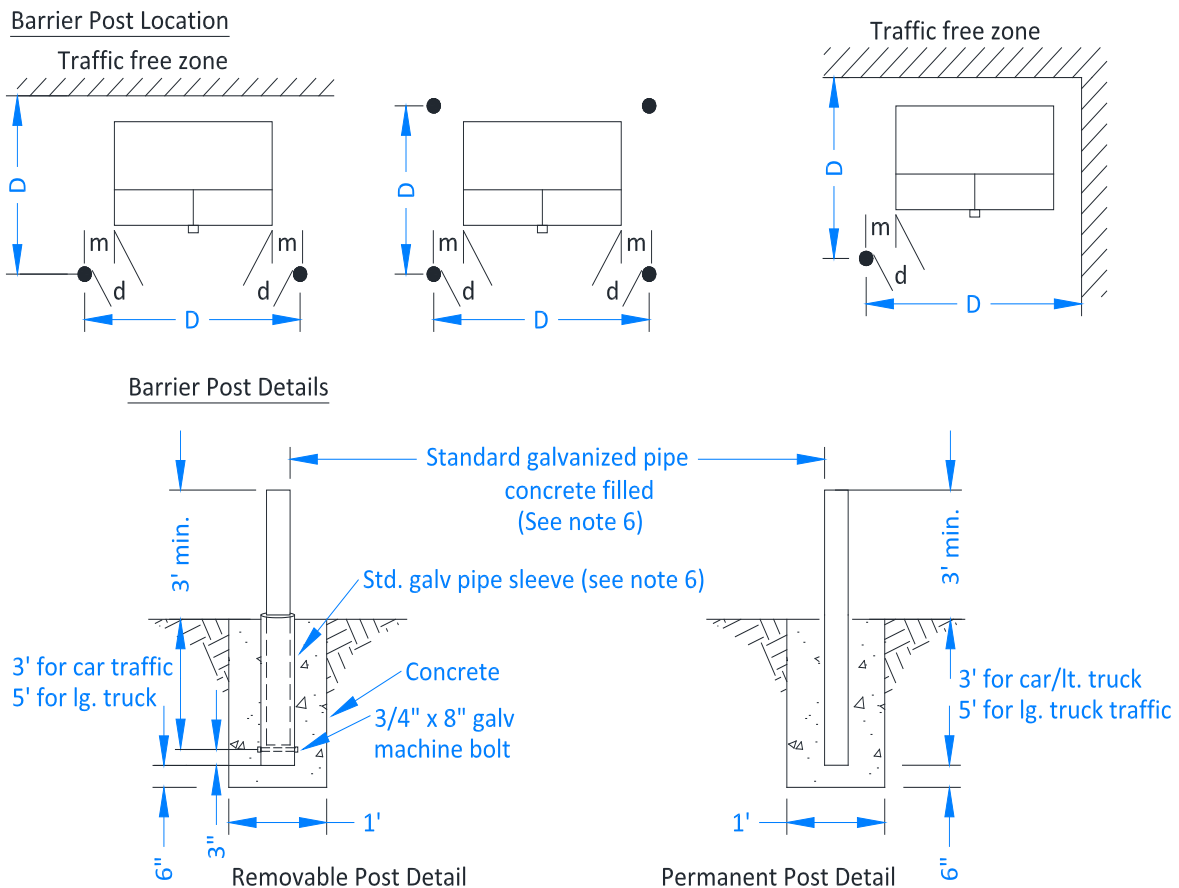
Sleeve base is 50x52 ½ inches. Consumer/contractors to provide 6 foot by 6 foot rough opening by 4 foot deep. Conduit should be set 18 inches to 24 inches from the front of the trench (remaining rough opening to back of box site).

## 9.16 BARRIER POSTS FOR PROTECTION OF PAD MOUNTED APPARATUS

If pad mounted apparatus is to be located in an area subject to vehicle traffic, suitable barrier posts are to be supplied and installed by the consumer in accordance with the special requirements below. If the apparatus is located in an area which will not ultimately be subject to vehicle traffic, but is in the path of construction equipment, temporary barriers complying with these same standards need to be provided by the consumer until the hazard of the apparatus being struck no longer exists.

**Figure 9.16.1 – Barrier Post Installation Requirements**

*See Special Requirements below for letter designations referenced in drawing*



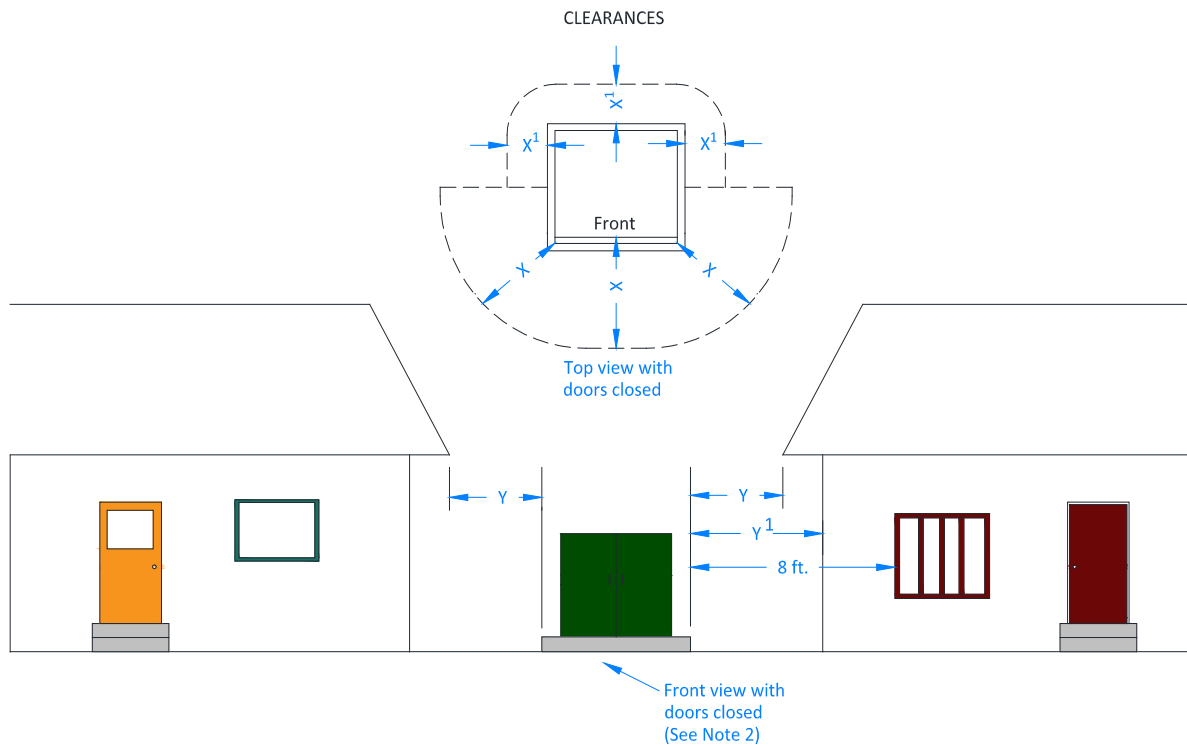
### **Special Requirements:**

1. The barrier posts need to be set at the corners of the pad mounted apparatus in traffic areas as shown above.
2. Distance "d" needs to be sufficient to allow the swinging doors on the apparatus to be opened fully. This minimum distance will be furnished by OTEC prior to the installation of the apparatus.
3. The distance "D" between barrier posts shall not exceed 6 feet. When exposed area exceeds this distance an intermediate post needs to be added.
4. Distance "m" needs to be a minimum of 2 feet.

5. Posts to be painted bright yellow.
6. Use 4 inch galvanized pipe for automobile and light truck traffic. Use 6 inch galvanized pipe for large truck traffic.

## 9.17 PAD-MOUNTED TRANSFORMER CLEARANCES

Figure 9.17.1 – Pad Mounted Transformer Minimum Clearance Requirements



### MINIMUM DISTANCE REQUIRED FROM PAD

- $X^1$  = 3 ft. clear area in back of unit to allow for required work space. (See Note 2)
- $X$  = 10 ft. clear area in front and sides of unit to allow working with hot sticks.
- $Y^1$  = 8 ft. from any transformer surface if structure is of combustible material.
- $Y$  = 3 ft. to non-combustible buildings surfaces having no openings closer than 8 ft.

### NOTES:

1. Consult OREGON ADMINISTRATIVE RULES 814-22-700 (electrical specialty code) and local building and fire codes for more consumer information.
2. Front of pad-mounted transformer to be located away from building walls or other barriers to allow for safe working practices. If front of transformer must face wall, allow "x" dimension for working area.
3. Consult utility for additional clearances that may be required to building doors, windows, fire escapes, and air vents etc.
4. Where pad-mounted transformers or other equipment is installed in a location where it might be struck by a motorized vehicle the consumer is to install and maintain OTEC approved barrier posts to protect the equipment.



# **OREGON TRAIL ELECTRIC CO-OP**

## **ELECTRIC SERVICE REQUIREMENTS & GUIDELINES**

### **INDEX**

Application for Service	6
Attachment, Service, Minimum Height	44
Balconies, Clearance of Service from	15
Cabinet, Current Transformer	29, 33, 59, 61
Circuit Closing Devices	31-32
Clearances, Overhead Service	15
Clearances, Underground Service from Swimming Pool	21
Cogeneration	41
Conductor, Supplied by Utility	9
Conductor, Identification by Color	10
Conduit, Furnished by Consumer	17-20, 52-53, 56-57
Conduit, Size and Type Required	17-20
Conduit, Current Transformer Metering	33-35, 59
Current Transformer Metering	24-25, 59
Current Transformer Metering, Residential, Underground Service	21-22, 29-31
Consumer Equipment Not Allowed on Poles	13
Disconnection of Service	12
Driveways, Clearance of Service over	15
Fault current Available	42
Generation, Parallel	41
Generation, Consumer-Owned	41
Guy, Service Mast	47
Interfering Loads	39-40
Load Information	35
Meter, Location	11-12

# **OREGON TRAIL ELECTRIC CO-OP**

## **ELECTRIC SERVICE REQUIREMENTS & GUIDELINES**

### **INDEX**

Meter, Reactive Demand	35
Meter, Supplied by Utility	9
Meter Socket, Clearance Requirements	45-46, 62
Meter Socket, Minimum Size	23-25
Meter Socket, Supplied by Consumer	11-12, 27-30
Meter Socket, Connections, Current Transformer	34-35
Meter Socket, Connections, Self-Contained	31-32
Meter Socket, Suggested List	29-30
Meter Socket, Enclosure Meter Socket, Mounting	31-32
Meter Socket, Limits	31-32
Metering, Current Transformer	33-34
Metering, Self- Contained	7, 30
Meters, Multiple	9, 49, 63
Mobile Homes, Overhead Service	14, 16, 50
Mobile Homes, Underground Service	21-23, 51, 56-58
Motor Protection	39
Motor, Single-Phase	36-37
Motor Starting	39-40
Multiple-Family Residences, Overhead Service	9, 16, 49, 63
Multiple-Family Residences, Underground Service	9, 21-22, 63
National Electric Code	6, 9, 12, 61
National Electrical Safety Code	6, 15, 49
Neutral, Identification by Color	10
Notification Required for Request for Service Changes	6-7
Offices, Location of OTEC	iv
Overhead Clearances	15, 43-45, 47-49
Overhead Service, Mobile Homes	16, 50-51
Overhead Service, Multiple-Family	16, 49
Overhead Service, Nonresidential	16
Overhead Service, Residential	16, 44-45
Overhead Service Drop	9, 14-16, 44-45, 50-51

# **OREGON TRAIL ELECTRIC CO-OP**

---

## **ELECTRIC SERVICE REQUIREMENTS & GUIDELINES**

### **INDEX**

Parallel Generation	41-42
Point of Delivery, Poles, See Service Poles	9
Power Factor	40
Power Leg, Identification by Color	10
Primary Voltage Service	26
Protection, Motor	39
Pulse Initiators / Load Information	35
Reactive	35, 40
Reduced Voltage Starters	39-40
Relocation of Service	13
Request for Service Residential	6-7
Overhead Service	44
Residential Underground Service	17-23, 46, 51-54
Right-of-Way, Furnished by Consumer	43
Safety, Consumer Responsibility	43
Seals, Meter	8
Sealing of Cabinets and Gutters	10
Service, Application for	6-7
Service, Overhead	9, 14-16, 27, 44, 47-51
Service, Poles	14, 16, 20, 26, 31, 47-50, 54
Service, Primary Voltage	26
Service, Temporary Overhead	12, 50-51
Service, Temporary Underground	12
Service, underground	21-25, 51
Service, clearances	15
Service Connection or Disconnection	12
Service Drop, Supplied by Utility	9, 14
Service mast	14, 47-49
Service Relocation	13
Single-Phase Service	7, 27-28, 30, 35, 38-39
Streets, Clearance of Service Over	15
Swimming Pools, Clearance of Service Over	21



# **OREGON TRAIL ELECTRIC CO-OP**

---

## **ELECTRIC SERVICE REQUIREMENTS & GUIDELINES**

### **INDEX**

Swimming Pools, Clearance from Underground Lines	21
Switches, Supplied by Consumer	9, 13, 25, 40-41, 52, 56
Switches, Supplied by Utility	34-35
Telephone Numbers of OTEC Offices	iv
Temporary Service	12
Terminal Box Installation	22, 24-25
Three-Phase Service	36, 38
Transfer Switches	40
Transformer, Barrier Posts for	21, 23, 60, 65, 67
Transformer Installation	7, 9, 11, 16, 21, 23, 26, 39, 67
Trenches, Supplied by Consumer	17-21, 23, 52, 58
Underground Service	21-25, 51
Underground Service, Commercial	23-25
Underground Service, Industrial	23-25
Underground Service, Mobile Homes	21-23, 56-58
Underground Service, residential	21-22, 52-54
Voltages Available	7
Voltages, Primary	26
Voltage-Sensitive Equipment	36